

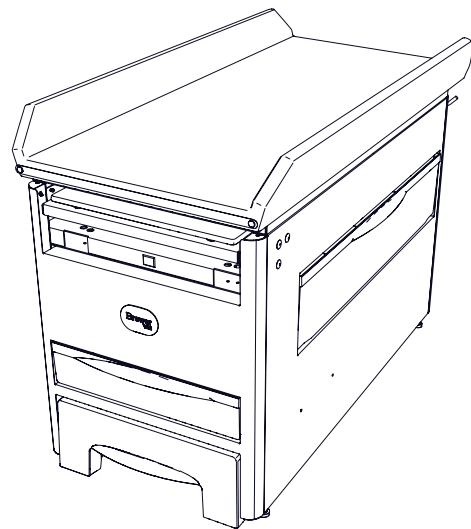

Model 1000

Installation and Operation Manual

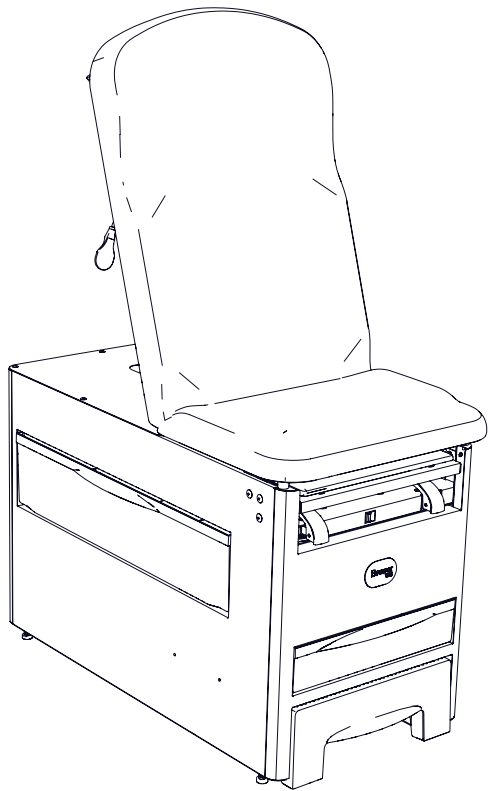

<i>Safety Information</i>	2	<i>Table Adjustments</i>	16
<i>Important Information</i>	3	<i>Maintenance</i>	20
<i>Component Identification</i>	4	<i>Accessories</i>	21
<i>Specifications</i>	5	<i>Warranty</i>	21
<i>Installation</i>	7	<i>Manuals in Other Languages</i>	21
<i>Operation</i>	12		

Registering your Brewer product is easy.

Simply go to brewercompany.com/contact/warranty-registration, fill out the information fields and click send.

By registering your product today, you are better safeguarding your investment in the future.

The Brewer Company, LLC
N88 W13901 Main Street, Suite 100
Menomonee Falls, WI 53051 USA



SAFETY INFORMATION

Safety Information



The primary concern of The Brewer Company is that the equipment is operated and maintained with the safety of the patient and healthcare staff in mind. To ensure safe and reliable operation:

- Read and understand all instructions in this manual before attempting to install or operate the unit.
- Ensure that appropriate personnel are informed on the manual contents. This is the responsibility of the purchaser.
- Ensure that this manual is located near the table, or if possible permanently affixed to the table.

Definitions

- **WARNING** indicates a hazardous situation which, if not avoided, could result in death or serious injury.
- **CAUTION** indicates a hazardous situation which, if not avoided, could result in minor or moderate injury.
- **NOTICE** indicates a situation not related to physical injury which, if not avoided, could result in equipment or property damage.

Symbols

	Yellow triangle with black border and black symbol warns of a hazardous situation.
	Blue circle with white symbol requires mandatory action to avoid causing a hazardous situation.
	Red ring with diagonal bar and black symbol prohibits an action that may cause a hazardous situation.

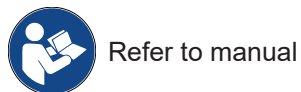

Refer to manual

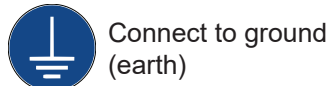

Connect to ground (earth)

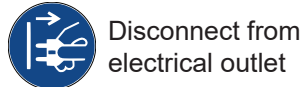

Disconnect from electrical outlet



Manufacturer

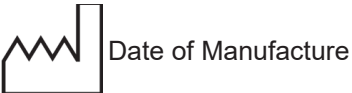

Date of Manufacture

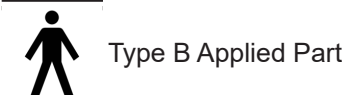

Type B Applied Part

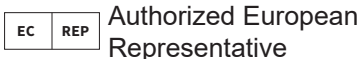

Authorized European Representative



Shock hazard



Fall hazard



Explosion hazard



Fire hazard



Pinch hazard



Trip hazard



Do not push



Do not sit



Do not step

IMPORTANT INFORMATION

General

The highly configurable Brewer Versa Examination Table is designed to serve patients of all ages, from newborn to elderly. Versa offers two upholstery top options, a standard adult and pediatric top, that can be interchanged as the patient population changes over time. Additionally, the table can be equipped with a variety of options and accessories, including patient assist handles, stirrups, drawer warmer, pelvic tilt, electric receptacle, knee crutches and more. The ergonomically placed extra-large side drawer and strategically placed front drawer provides ample storage space.

Intended Use

Versa products will be sold into the physician office market and are intended to be used by healthcare professionals employed by physician offices, medical clinics, and IDNs. Versa products will be used to examine a wide variety of patients of various sizes and mobility. Versa will be used inside of an office/clinic and require no special environmental needs.

Please visit Brewer Company's website brewercompany.com/resources to find this manual translated into additional languages.

Registering your Brewer product is easy. Simply go to brewercompany.com/contact/warranty-registration, fill out the information fields and click send. By registering your product today, you are better safeguarding your investment in the future.

Any serious incident that has occurred in relation to the device should be reported to the manufacturer and the competent authority of the Member State in which the user and/or patient is established.

Brewer's authorized European representative is:

Emergo Europe
Westervoortsedijk 60
6827 AT Arnhem
The Netherlands



Expected Life

Expected life of product is five years.

Service

If you require assistance with the installation or operation of your Brewer Table, call the Brewer Customer Experience Department at **1-800-558-8777**. Our trained staff will attempt to assist you in correcting the problem directly over the phone. If service is required, a factory authorized technician may be sent to your location.

Please fill in the following information for use when calling The Brewer Company or your distributor with questions regarding your unit. See Figure 1 for model and serial number location.

Date of Purchase _____

Serial Number _____

Model Number _____

Authorized Dealer Name _____

Dealer Phone Number _____

Dealer Address _____

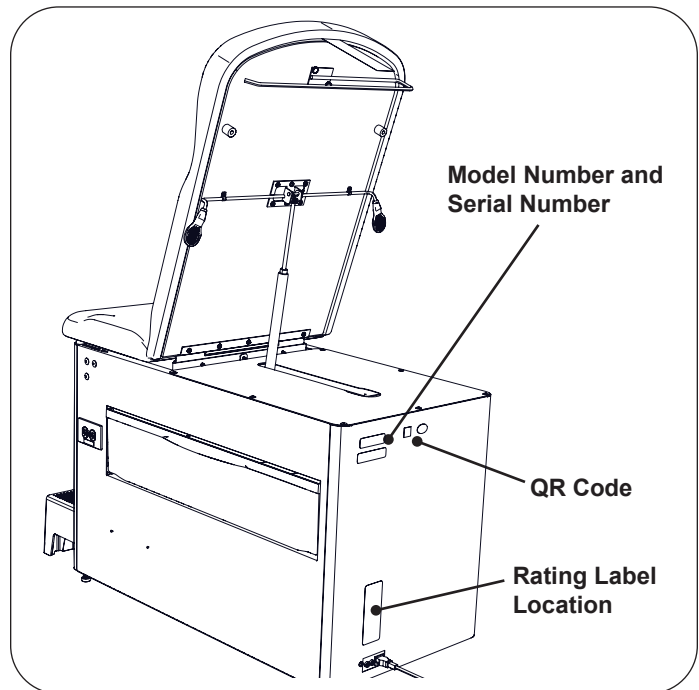

Figure 1. Model Number, Serial Number and Rating Label Locations

COMPONENT IDENTIFICATION

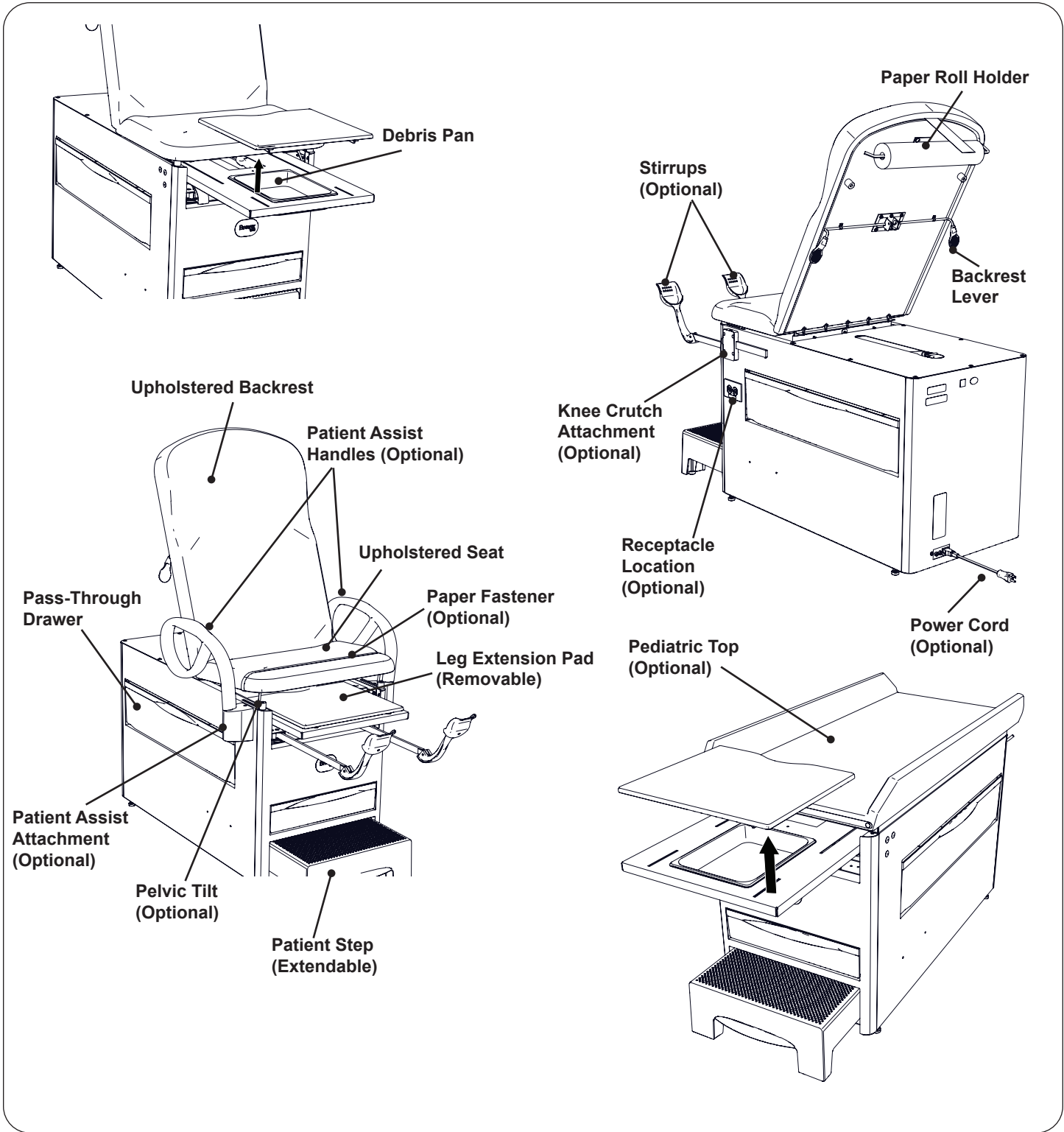

Figure 2. Component Overview

SPECIFICATIONS

Weight of Table 250 lbs.

- With carton and skid..... 290 lbs.

Stirrups Extension (maximum) 16 in.

Stirrups Lateral Positions 4 Lateral Positions

Leg Extension (maximum) 14 in.

Dimensions

- Upholstered top..... 27.3 in. wide x 58.0 in. long
- With leg extension fully extended..... 72.0 in.
- Seat height..... 32.5 in.
- Step..... 7.8 in. high x 18.2 in. wide x 15.2 in. long

Load Rating (maximum)

- Seat/Back..... 500 lbs.
- Leg Support..... 50 lbs.
- Step..... 500 lbs.
- Grab Bars (optional)..... 100 lbs.

Base 29.2 in. high x 23.3 in. wide x 46.1 in. long

Transportation and Storage

- Temperature 18°F to 176°F
- Humidity -10% to 90%

Operation

- Temperature 50°F to 100°F
- Humidity 30% to 75%
- Pressure 1 atm

Electrical Requirements

- **120V models:** 120 VAC nominal, 60 Hz, 3 Amps maximum including maximum 2 Amp accessory outlet
- **240V models:** 240 VAC nominal, 50/60 Hz, 3 Amps maximum including maximum 2 Amp accessory outlet

Fuse Rating 3 Amp/250V

Power Cord

- **120V models:** 10 ft., 3 conductor, 125 VAC with hospital grade plug
- **240V models:** 10 ft., 3 conductor, 250 VAC

Type of protection against electrical shock..... Class 1

Type of protection against electrical shock B applied parts

Type of protection against ingress of water Ordinary

Can accept paper rolls of either 21 in. x 3.5 in. dia.
60 cm x 15 cm dia.

Certifications... AAMI ES60601-1 (2005) + AMD 1 (2021), IEC60601-1 Ed. 3.1, CAN/CSA - C22.2 No. 60601-1 (2014)

Pelvic Tilt 5° rise

Drawer Warmer

- **120V models** 120 VAC, 60W, 0.5 Amps
- **240V models** 240 VAC, 60W, 0.25 Amps

NOTICE: CERTIFICATIONS

This product has been evaluated with respect to electrical shock, fire, and mechanical hazards only in accordance with AAMI ES60601-1 (2005) + AMD 1 (2021), IEC60601-1 Ed. 3.1, CAN/CSA - C22.2 No. 60601-1 (2014).

 *Classified in the United States and Canada per the standards listed above.



SPECIFICATIONS (CONTINUED)

EMC - Manufacturer's Declaration

Immunity Test	Immunity Test Level
Electrostatic Discharge	+/-6 kV contact +/-8 kV air
Radiated RF EM Fields	3 V/m 80 MHz - 2.5 GHz 80% AM at 1 kHz
Rated Power Frequency Magnetic Fields	50 Hz and 60 Hz 3 A/m
Electrical Fast Transients Surges	+/-2 kV at 100 kHz repetition frequency Line-to-line: +/-2 kV Line-to-ground: +/-2 kV
Conducted RF	0.15 MHz - 80 MHz at 3 V ISM bands between 0.15 MHz - 80 MHz at 6V 80% AM at 1 kHz
Voltage Dips	0% UT; 0.5 cycles at 0°, 180° 40% UT; 5/6 cycles at 0°, 180° 70% UT; 25/30 cycles at 0°, 180°
Voltage Interruptions	0% UT; 250/300 cycles at 0°
Emissions Test	
Conducted and Radiated RF Emissions	Emissions Test Level CISPR 11 Group 1 Class B

Voltage, Current, Frequency Ratings, and Compliance Chart

Model	Description	Standards:		Electrical Ratings:		
		ES 60601-1	CAN / CSA C22.2, 60601-1	VAC +/-10%	Amps	Cycles (Hz)
1000XX-XXXX-RXX-XX	120V Outlet	X	X	120	3.0	60
1000XX-XXXX-RHX-XX	120V Outlet & Heater	X	X	120	3.0	60
1000XX-XXXX-2XX-XX	240V Outlet	X	X	240	3.0	50/60
1000XX-XXXX-2EX-XX	240V Outlet & Heater	X	X	240	3.0	50/60

INSTALLATION

NOTICE: No Sharp Tools

To avoid damaging the table's upholstery or painted surfaces, **DO NOT** use a knife or other sharp object to open the packaging.

NOTICE: Inspect Carton and Contents

Inspect all boxes and contents for damage. Report any damage to the carrier immediately.

NOTICE: AVOID HANDLING DAMAGE

- To avoid damaging the table lift only at points indicated in Figure 3.
- Do not use stirrup or stirrup beams for lifting table.
- Do not use the knee crutch receivers or patient assist handles for lifting table.

Overview

Perform the following sequence in order when setting up the table:

- Uncrating the Table
- Leveling the Table
- Installing the Easy Connect Upholstered Top
- Installing the Paper Roll Holder
- Powering the Table

NOTICE: Optimum Table Performance

For optimum table performance, allow the table to reach room temperature before operating.

Uncrating

Tools Required

- 1/2" socket wrench

Hardware Required

- None

Instruction

1. Carefully remove outer carton by removing the staples along the bottom of the carton and lift off table.
2. Unbolt the table from the shipping pallet by removing the 4 bolt screws from the pallet with a 1/2" socket wrench and remove the shipping bracket. See Figure 3.
3. Remove plastic surrounding table. **DO NOT** use a knife or any sharp object that could damage the upholstery.
4. Remove the table from the shipping pallet lifting at the correct lift points indicated in Figure 3. This requires two people to lift the table. The leg extension may be used for lifting.

NOTICE

Table weighs approximately 250 lbs.

5. Position the table in the desired room location.

NOTICE

Power cord should remain accessible in order to disconnect the unit from the power supply.



CAUTION: Trip Hazard

Do not position the power cord where it may be tripped over.

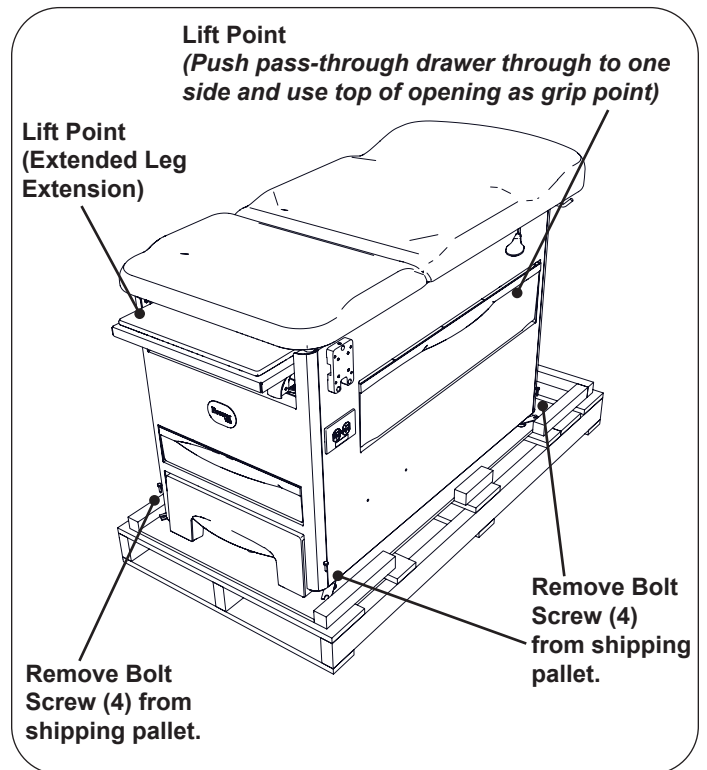

Figure 3. Table Lift Points

INSTALLATION (CONTINUED)

Leveling the Table

Tools Required

- Pry bar
- Wooden block

Hardware Required

- None

Instruction

A leveling screw pad is located at each table corner under the table's base (see Figure 4). Adjust the four leveling pads by turning them up or down, using Method 1 or Method 2 to achieve a solid, level installation. Test step by pulling out. If step drags on floor or is difficult to pull out, adjust the rear table levelers out 1 turn at a time until step pulls out easily.

Method 1 - Raise corner of table using a pry bar on a wooden block. Insert another wooden block under corner. Adjust leveler, and remove corner block.

Method 2 - Two people raise rear of table by pushing the pass-through drawer to one side and using the drawer opening as a hand hold.

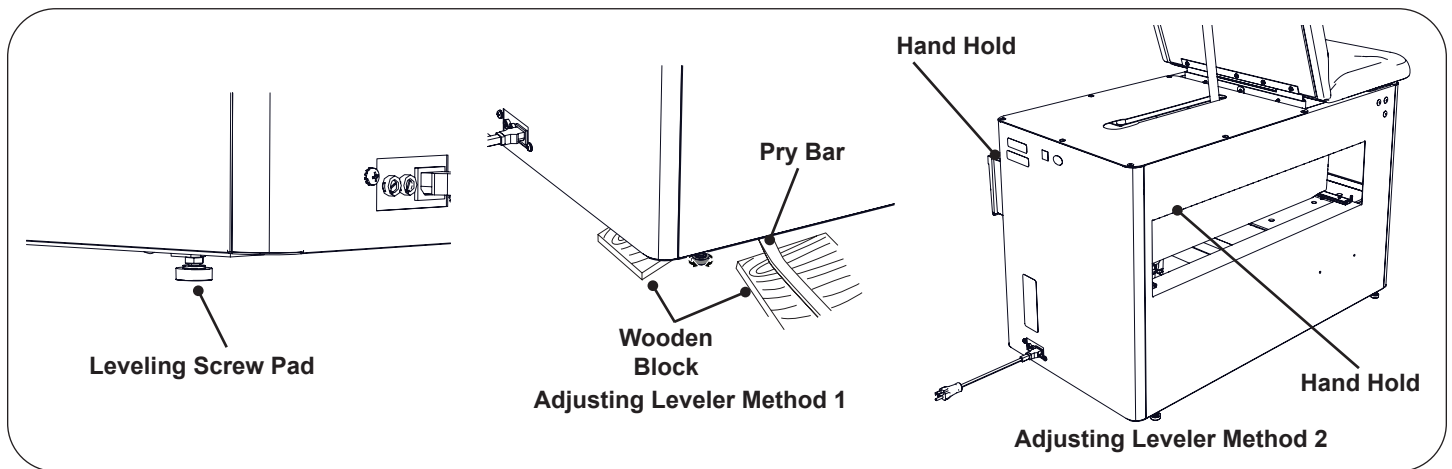

Figure 4. Leveling Screw Pad (located under table)

INSTALLATION (CONTINUED)

Install the Easy Connect Upholstered Top

Tools Required

- None

Hardware Required (Included)

- 3 x thumb screw, 1/4-20 x 5/8
- 1 x pin, clevis .25 dia x 1.88 lg
- 1 x pin, cotter .06

Instruction

1. Partially install one thumb screw in the center location of the hinge slot on the cabinet. The thumb screw may be preinstalled. **DO NOT** install fully – leave .25-.50 in. [6-12 mm] of space.
2. Place the upholstery assembly on top of the cabinet. The seat-end (short-end) of the assembly should be oriented toward the front of the cabinet (end with the patient step).
3. Lift the seat-end of the upholstery assembly and align the hinge plate with the hinge slot on the top of the cabinet.
4. Place the hinge plate into the hinge slot on the cabinet with the center “V”-shaped cutout straddling the partially-installed thumb screw. The hinge plate should “bottom-out” in the hinge slot.
5. Partially install the remaining two thumb screws – one on each side of the center thumb screw.
6. Fully tighten the center thumb screw.
7. Fully tighten each of the two remaining thumb screws.
8. Lift the backrest-end of the upholstery assembly and lift the gas cylinder up into the clevis-actuator mount located on the back surface of the backrest. Use the clevis pin and cotter pin to fasten the gas cylinder in place. The position of the actuator rod should be as shown below.

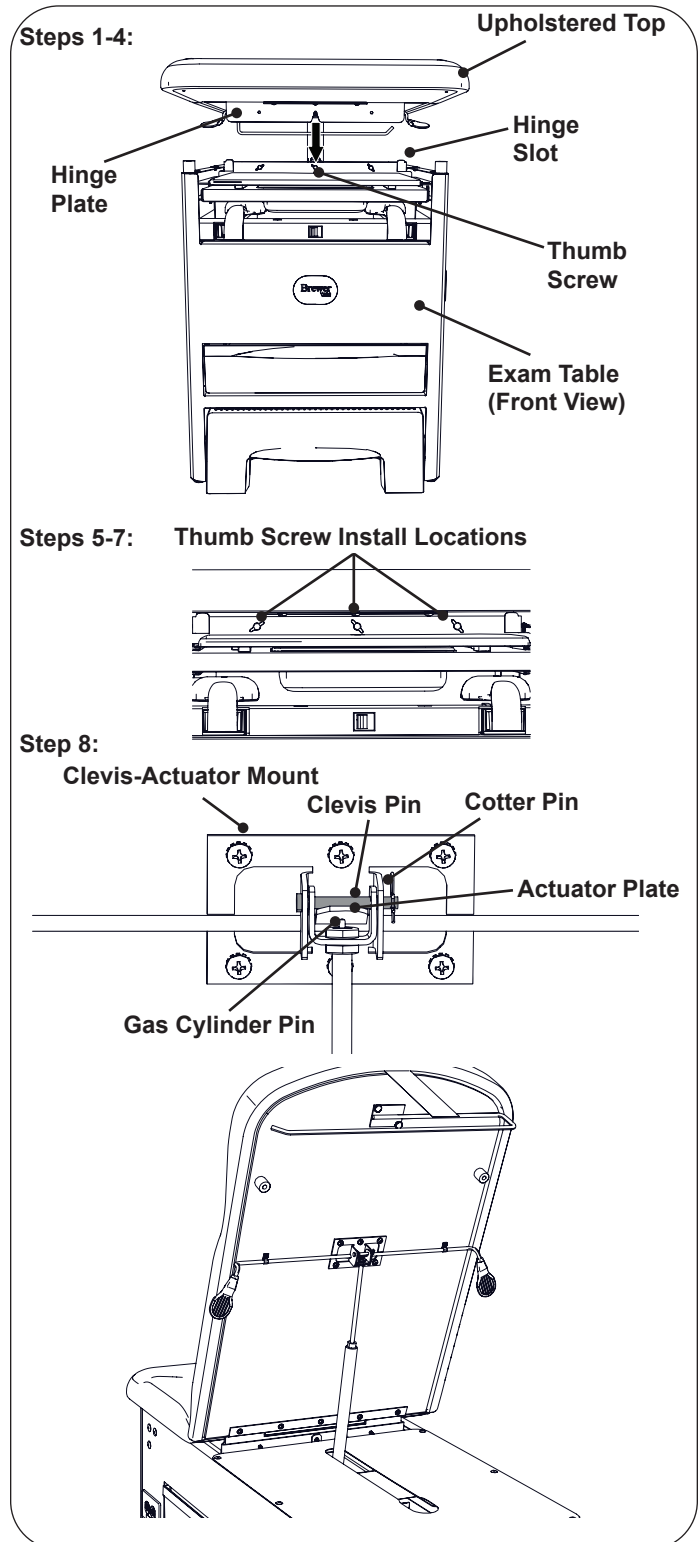

Figure 5. Installing the Upholstered Top

INSTALLATION (CONTINUED)

Installing the Patient Assist Handles

For tables ordered to include the Patient Assist Handles, all components are packaged within a box that can be found stretch-wrapped to the back end of the table.

Tools Required

- 7/16" Hex head wrench or driver

Hardware Required (Included)

- Patient assist handles (x2)
- Assist handle mounts (x2)
- Hex head bolts (x8)
- Mount covers (x2)
- Plastic push rivets (x6)

Instruction

1. Align the assist handle mount with the hole pattern on the mounting plate (pre-installed on the table). Be sure that the slotted end of the assist handle mount is facing up. Use 4 hex head bolts to fasten the mount to the plate. (See Figure 6)
2. Slide the mount cover over the assist handle mount with the keyhole cutout facing up. Align the top mounting hole with the hole in the top of the mounting plate. Insert one plastic push rivet and push down with thumb until flush with top of the cover (see Figure 6).
3. Insert push rivets into two more mounting holes on the underside of the cover, again pushing in with thumb until flush with cover.
4. Repeat steps for other side of table.

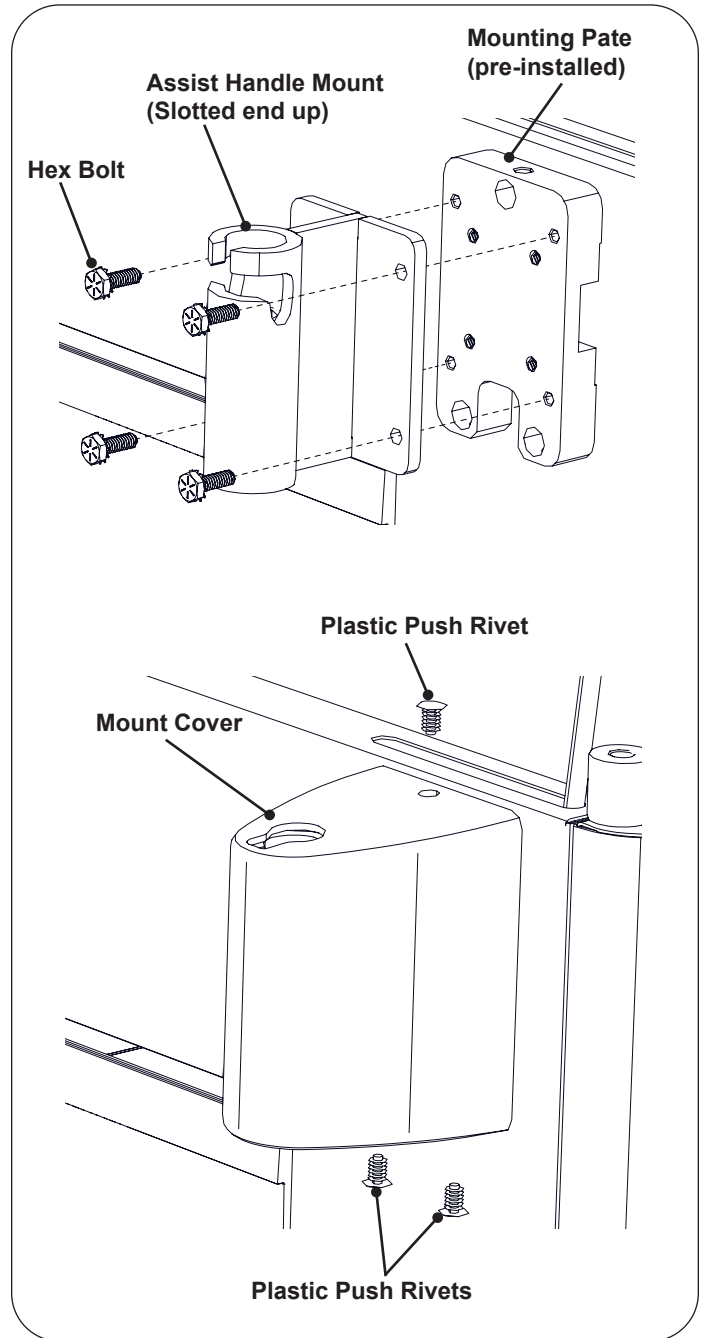

Figure 6. Installing the Patient Assist Handles

INSTALLATION (CONTINUED)

Installing the Paper Roll Holder

Tools Required

- None

Hardware Required (Included)

- 2 x thumb screw, 1/4-20 x 5/8

Instruction

1. Determine which orientation is desired for the paper roll holder. (See two options in Figure 7.)
2. Place the paper roll holder in the desired orientation.
3. Install each of the two thumb screws diagonally from each other.
4. Fully tighten both thumb screws.

Powering the Table

Plug the male end of the power cord into a grounded receptacle.

	<p style="text-align: center; margin: 0;">CAUTION</p> <p>Do not use an extension cord on the accessory receptacle.</p>
---	---

	<p style="text-align: center; margin: 0;">CAUTION</p> <p>Only connect items compatible to the exam table to the accessory receptacle.</p>
---	--

<p style="text-align: center; margin: 0;">NOTICE: Confirm Voltage and Plug Type</p> <p>See Specifications page for electrical rating of this unit.</p>	
---	--

	<p style="text-align: center; margin: 0;">CAUTION: Use Grounding Plug</p> <p>To avoid risk of electric shock, connect this equipment to a supply mains with protective earth. Plug the grounding plug on the table power cord into a matching grounded, non-isolated, correctly polarized receptacle.</p>
---	--

<p style="text-align: center; margin: 0;">NOTICE: Electromagnetic Interference (EMI)</p> <p>This product is designed and built to minimize electromagnetic interference with other devices; however, if interference is noticed between another device and this product, remove the interfering device from the room or plug this product into an isolated circuit.</p>	
--	--

	<p style="text-align: center; margin: 0;">WARNING: Shock Hazard</p> <p>After installing or moving table, make sure there are no damaged or exposed wires that could result in electrical shock.</p>
---	--

Note: All power cords should be supplied by The Brewer Company.

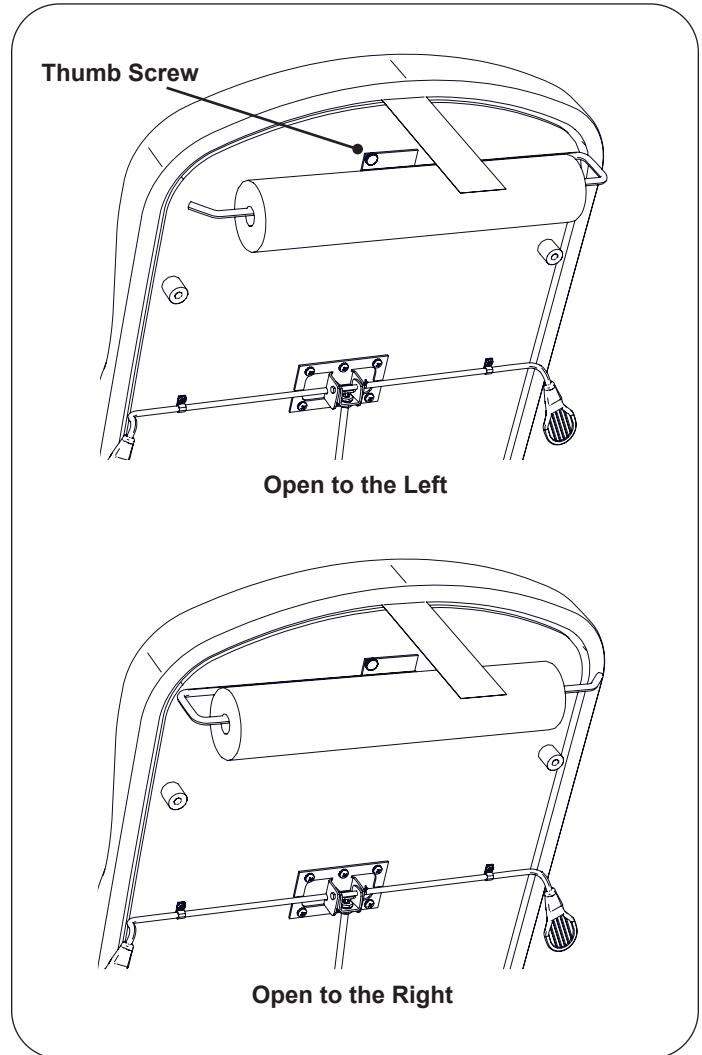





Figure 7. Installing the Paper Roll Holder

OPERATION

Before Use

	<p>CAUTION: Read this Manual</p> <p>Read this manual before use of the Brewer Versa Examination Table.</p>
---	---

	<p>WARNING: Explosion/Fire Hazard</p> <p>Do not use this table in an explosive or oxygen rich atmosphere. Doing so may result in serious personal injury or death.</p>
---	---

	<p>WARNING: Shock Hazard</p> <p>When performing cauterization or similar treatment, the patient must be insulated from the metal portions of the table by non-conductive material. Failure to do so may result in electrical shock.</p>
---	--

Leg Extension

The leg extension is located under the seat cushion (Figure 8). It can be extended 14" for the patient prone position. Pull leg extension out to the desired position. The leg extension pad will extend along with the leg extension. To return the leg extension to its stored position, simply push the leg extension in.

	<p>WARNING: Fall Hazard</p> <p>Do not allow patient to sit on the leg extension portion of the table. Doing so may result in serious personal injury or death.</p>
---	---

Leg Extension Pad

The leg extension pad can be slid beneath the seat with the leg extension extended for easy access to the debris pan (Figure 8). Pushing the leg extension back in will allow the glides on the pad to drop into slots. The pad will once again come out with the leg extension the next time it is pulled out.

Debris Pan

A removable debris pan is built-in underneath the leg extension pad for use during examinations (Figure 8). Pull the leg extension fully out and remove the leg extension pad or slide it back under the seat to access the pan. Remove the debris pan for cleaning.

<p>NOTICE: Avoid Liquid Spill</p> <p>Remove all liquid from debris pan before returning to table. Spillage from debris pan may cause damage to exam table.</p>

Front Drawer

A storage drawer for supplies is located at the front of the table (Figure 8).

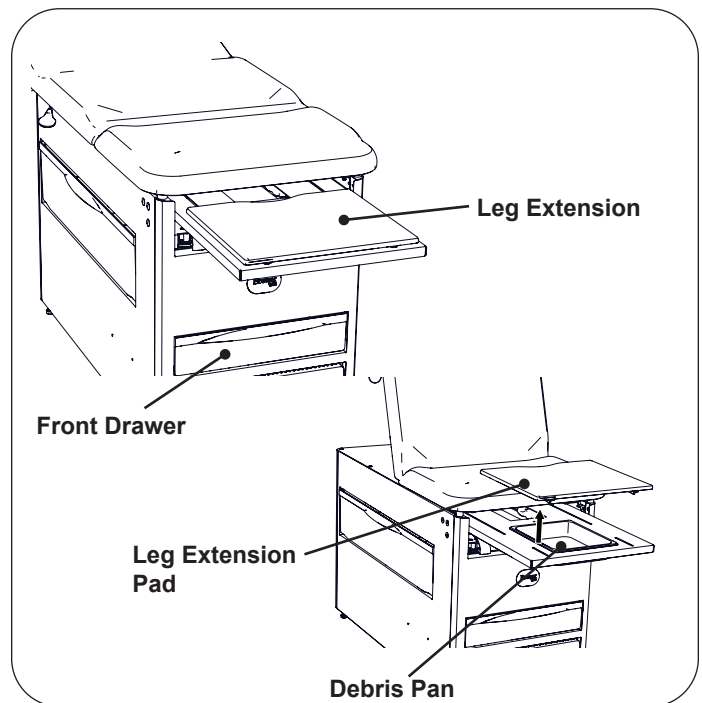

Figure 8. Leg Extension and Debris Pan

OPERATION (CONTINUED)**Patient Step**

1. Place hand or foot into opening in front of step and gently lift while fully extending patient step (Figure 9).
2. To retract step to stowed position, gently lift while pushing step fully back into cabinet.

**WARNING: Fall Hazard**

Fully extend patient step to provide ample area for the patient to stand on. Failure to fully extend patient step could result in a fall causing serious injury.

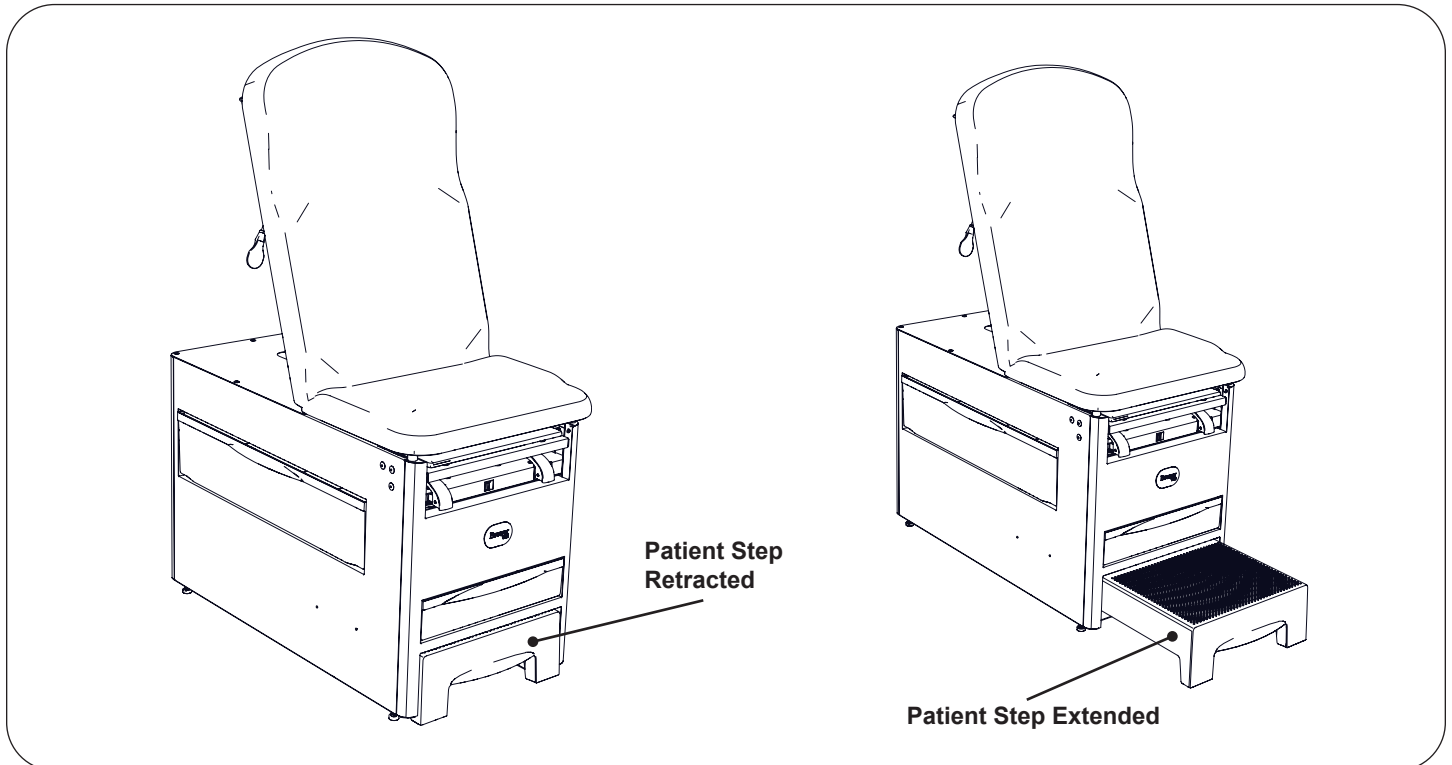

Figure 9. Operation of Patient Step

OPERATION (CONTINUED)

Adjustable Stirrups (Optional)

Operating the Stirrups

1. To operate the stirrups, grasp end of stirrup and pull straight out of the table (Figure 10). Lift up slightly while sliding the stirrup out.

NOTE: Applying downward pressure when pulling stirrup from table may make it difficult to move. Resistance is normal and is part of the stirrup friction locking mechanism.

2. Unfold stirrup upward to the fully open position.
3. Adjust the stirrup to the desired length by sliding it in or out.

Stirrup Lateral Adjustment

1. Lift end of stirrup slightly and then rotate outward to desired position.
2. When the desired position is achieved, lower the stirrup to engage the lateral locking mechanism (Figure 10 and Figure 11).
3. Check that lateral locking mechanism is engaged by attempting to move stirrup assembly side-to-side without lifting on the stirrup end.

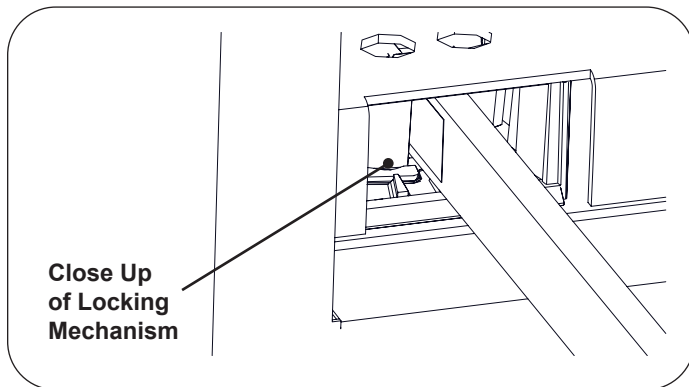

Figure 10. Stirrup Locking Mechanism

Storing the Stirrups

1. To store the stirrups in the table, grasp end of stirrup and pull straight out to its full extension.
2. Fold stirrup down against bar, then rotate it to the inner most lateral position and slide it back into the stowed position.

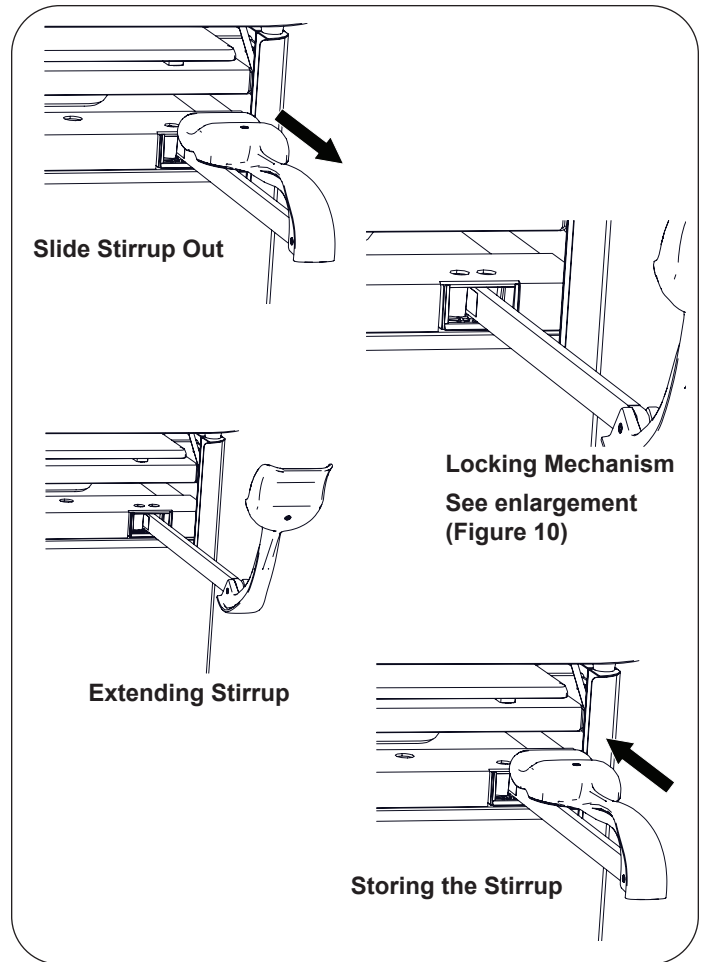
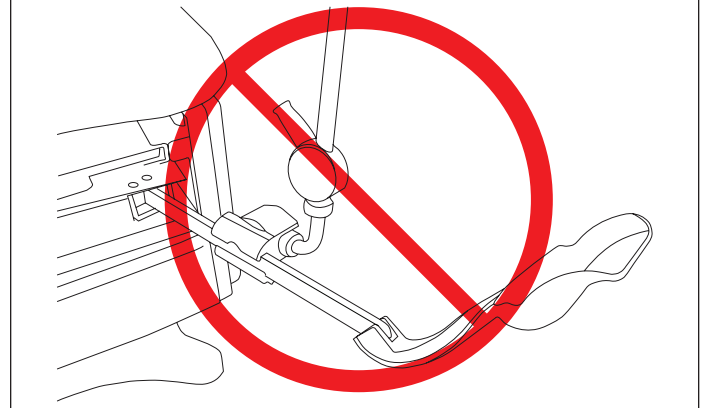

Figure 11. Stirrups

NOTICE: Use Stirrup Only as Designed

Do not use any part of the stirrup for attachment of any device. Warranty will be voided.



OPERATION (CONTINUED)

Operating the Patient Assist Handles (Optional)

1. To insert the patient assist handles into the mounts, partially insert shaft end into opening on top of mount. Rotate the handle until the pin on the shaft aligns with the slot and insert handle all the way down.

Note: the patient assist handles are interchangeable.

2. The patient assist handles have two locking positions: backward at 5° and forward at 175°. Position the bar in the desired position and the bar will fall into a locking detent at each of those positions.
3. To switch from one position to the other, lift the bar straight up until the bar is disengaged from the mount detent and rotate the bar outward from the table. The bar will fall into a locking detent at the other position.
4. Be sure the patient assist handles are in one of two locking positions before use. Applying force to the bars when not in one of two locking positions may cause the bar to move.



WARNING: Fall Hazard

Do not allow patient to sit on the assist handles. Doing so may result in serious personal injury or death.

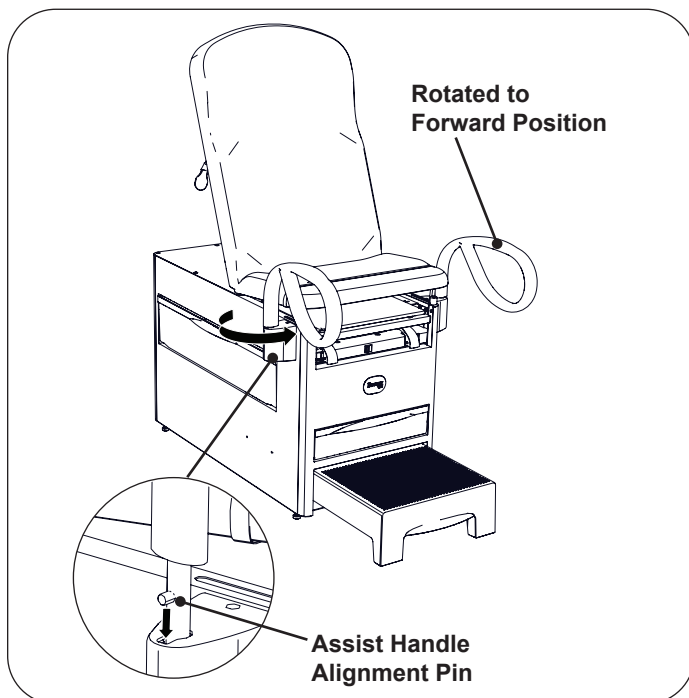

Figure 12. Handles Rotated in Forward Position

Operating the Knee Crutch Receivers (Optional)

1. The knee crutch receivers have two locking positions: rearward and forward. Position the bar in the desired position and the spring plunger on the underside of the mount will capture the bar and lock it in position.
2. To switch from one position to the other, pull the spring plunger ring and slide the bar. Release the spring plunger ring to capture the bar and lock it in position.

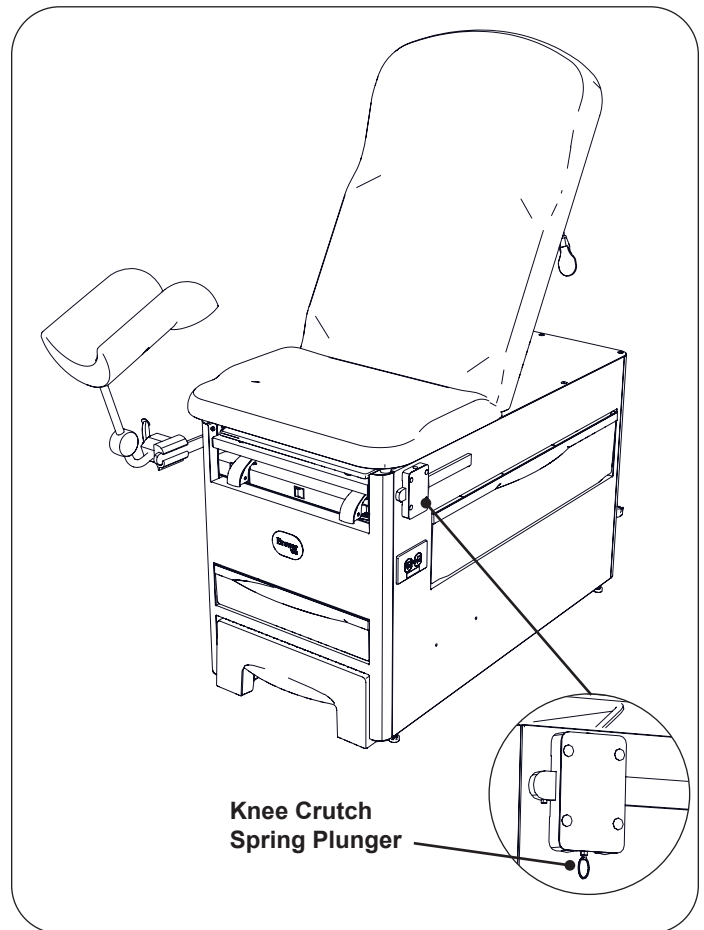



Figure 13. Knee Crutch Attachment

TABLE ADJUSTMENTS

Patient Positioning

The table is designed to accommodate the following examination positions (Figure 14):

- Chair Position
- Full Flat Table Position
- Lithotomy (Pelvic) Position

	<p>WARNING: Pinch Hazard Keep hands safely away from area between the upholstered table top and the table cabinet when adjusting positions.</p>
---	--

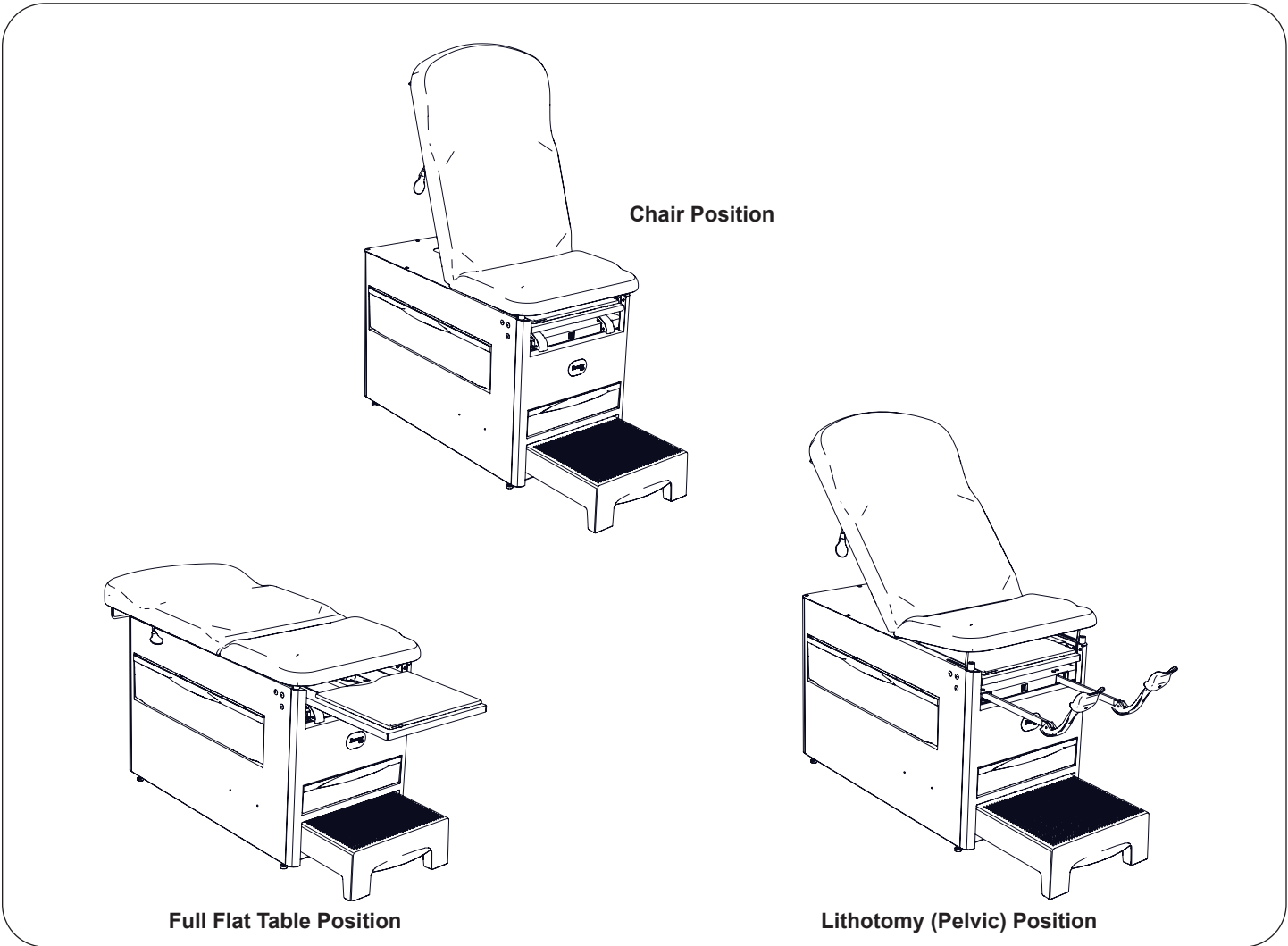

Figure 14. Patient Positioning

TABLE ADJUSTMENTS (CONTINUED)

Upholstered Backrest

1. Press and hold the backrest lever, lift upholstered backrest upward to raise (Figure 15). Releasing the lever will automatically lock the table in the desired position.
2. While actuating the backrest lever upwards, push down on the upholstered backrest to lower it.

**WARNING: Adjust Backrest with Care**

Use care when depressing the manual backrest lever while a patient is seated on the table. Adjust the backrest in increments by depressing and releasing the lever. Allowing the backrest to adjust in a single motion could cause injury to the patient.

**WARNING: Fall Hazard**

If actuator is not performing as intended, assist the patient from the table and refer to Service Manual.

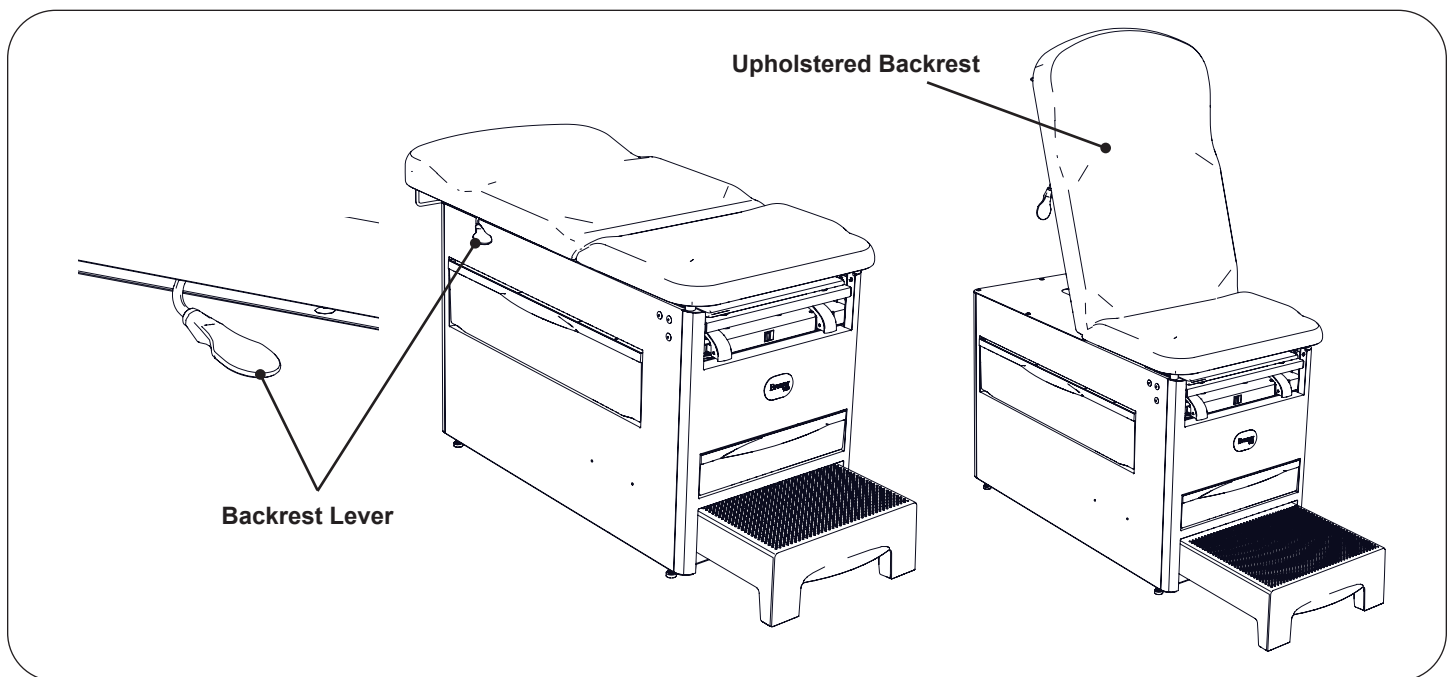

Figure 15. Operation of Upholstered Backrest

TABLE ADJUSTMENTS (CONTINUED)

Pelvic Tilt (Optional)

The pelvic tilt feature sets the seat angle at 0° (horizontal) or 5° (up) position.

Raising the upholstered seat to the Pelvic Tilt Position:

1. Raise the front edge of the upholstered seat (Figure 16). Rotate the pelvic tilt support bar upward to its full upright position.
2. Lower the upholstered seat onto the pelvic tilt support bar.

Lowering the upholstered seat back to the Normal Position:

1. Slightly raise the front edge of the upholstered seat.
2. Rotate the pelvic tilt support bar downward and lower the upholstered seat into its prone position.

NOTICE: Adjusting the Pelvic Tilt Mechanism

Patient must be removed from table prior to adjusting the pelvic tilt mechanism.



WARNING: Pinch Hazard

Keep hands safely away from area between the upholstered table top and the table cabinet when adjusting positions.

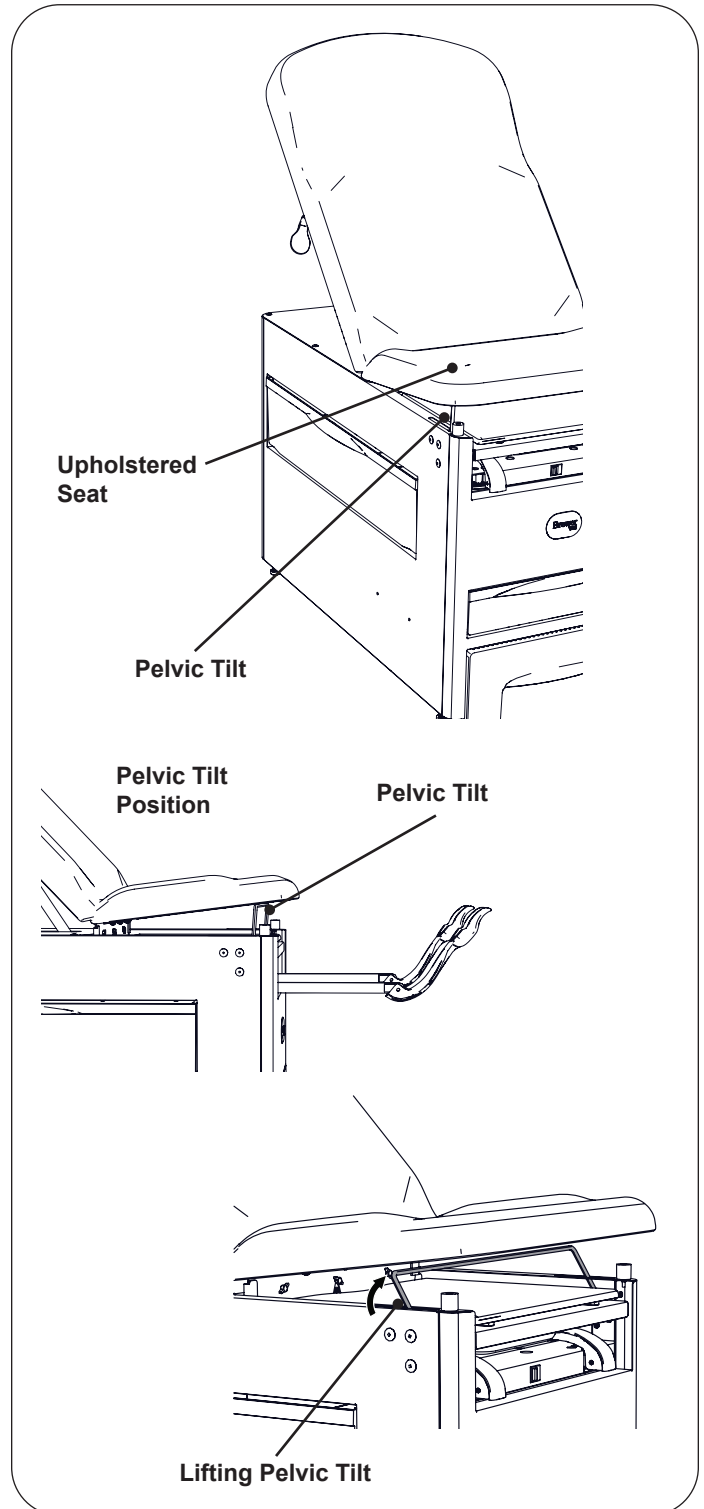

Figure 16. Pelvic Tilt Support Bar

TABLE ADJUSTMENTS (CONTINUED)

Drawer Warmer (Optional)

The drawer warmer warms the contents of the front drawer on the foot end of the table.

To operate the warmer, turn the warmer power switch to the ON or “illuminated” position (Figure 17). The switch will illuminate to indicate that the warmer is operating.

To turn the warmer off, turn the warmer power switch to the OFF or “non-illuminated” position.

NOTE: The warmer element is located below the drawer and applies radiant heat to the drawer contents. Items closer to the element will be warmer than items at the top of the drawer.

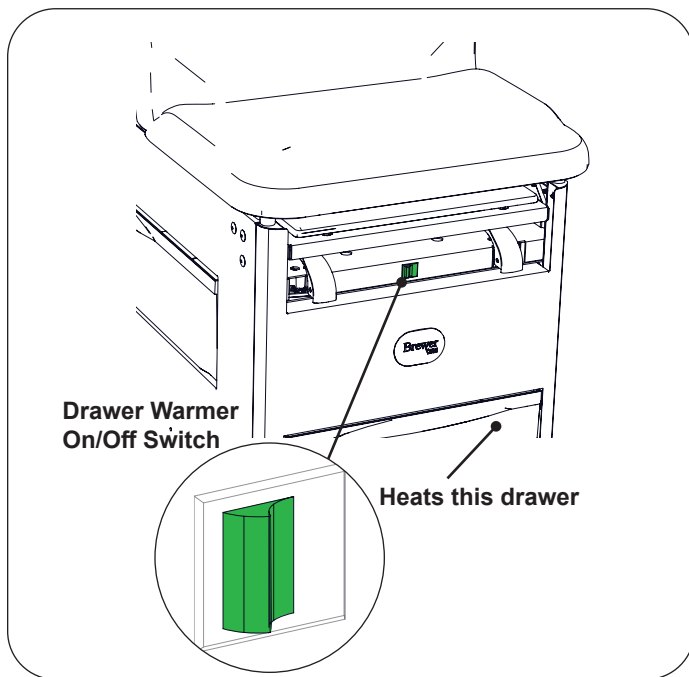

Figure 17. Drawer Warmer Switch

Electrical Receptacle (Optional)

Electric models are equipped with an electrical receptacle located on the left hand side of the table (Figure 18). The maximum total load that can be plugged into the receptacle is 2A.



CAUTION

Only use receptacle up to the 2A rating. Extension cords and power strips are not intended to be used.

NOTICE: Maximum Receptacle Rating

Plugging a device into the receptacle on the side of the table with rating higher than 2A may cause the fuse at the back of the table to blow.

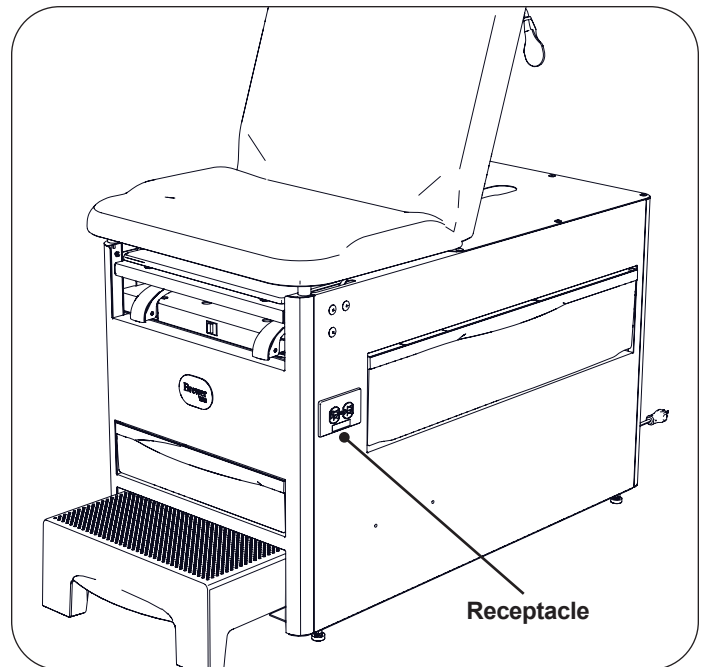



Figure 18. Table Receptacle

MAINTENANCE

	<p style="text-align: center;">WARNING: Shock Hazard</p> <p>Disconnect power by removing plug from wall receptacle before servicing table.</p>
---	---

	<p style="text-align: center;">CAUTION</p> <p>Only use the receptacle to supply power to equipment intended to form part of the medical electrical system.</p>
---	---

Preventative Maintenance

<p style="text-align: center;">NOTICE: Loose Fasteners and Damaged Components</p> <p>Failure to perform periodic inspections of the table could result in equipment damage.</p>
--

Inspect table every 6 months.

- Periodically inspect the electrical cord to ensure it is free of cuts or damage if equipped.
- Inspect the mechanical functions to ensure satisfactory operation.
- Check fasteners to make sure they are present and tightened securely.
- Lubricate moving parts (such as back hinge) with a food grade silicone lubricant. Cover surrounding area to protect from overspray. Wipe away excess lubricant. Do not lubricate beam or locking mechanism in stirrup area.

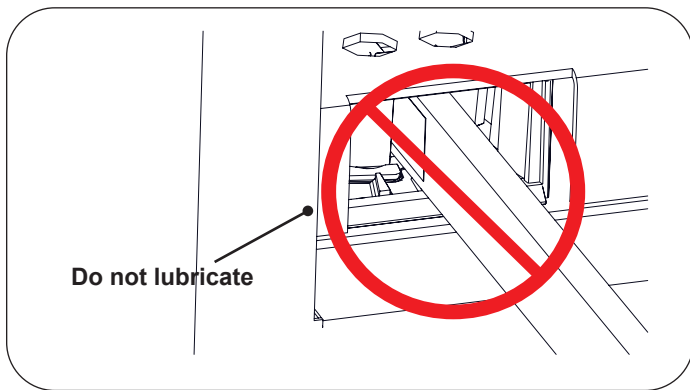

Figure 19. Do Not Lubricate Beam or Locking Mechanism

<p style="text-align: center;">NOTICE: Table Malfunction</p> <p>If table malfunctions, immediately unplug the power cord from the receptacle and assist the patient from the table. Service the table prior to use.</p>
--

Table Care

<p style="text-align: center;">NOTICE: Wipe Spills Immediately!</p> <p>The upholstery material is resistant to most medicinal type stains, but may be damaged by solvents and dyes. Remove any spilled fluids from the upholstery immediately.</p>

Improper cleaning products used on Brewer tables can decrease the life of the table. Always follow Brewer's Cleaning & Disinfectant guidelines. You can view the latest guidelines at brewercompany.com/resources.

Proper Disposal

Follow local and state guidelines for proper disposal of product.

Metal work can be recycled through licensed recycling facilities. Used electrical and electronic equipment (WEEE) should not be mixed with general waste within the United Kingdom or the European Union.

For further assistance, please contact your dealer.

ACCESSORIES

Listed below are the accessories which are authorized for use with this table.

Description	Order No.	Use/Restrictions
Front Drawer Dividers	3500288	Front drawer dividers for separation and organization.
Urology Drain Pan System	100253	Conveniently and safely captures fluids during urology procedures.
Stainless Steel Debris Pan	98464	Stainless steel debris pan to replace standard plastic debris pan.
Deluxe Articulating Knee Crutches with assembly kit (Field Install)	3500286	Knee crutches assist in positioning a patient on the exam table
Welch Allyn Green Series™ Exam Light IV Mounting Bracket (Field Install)	3500398	Field install mounting bracket kit.
Welch Allyn Green Series™ Exam Light IV Mounting Bracket (Factory Install)	3500447	Factory installed mounting bracket.
Paper Fastener for Adult Upholstery	3500305	Kit to install/replace the paper strap on the adult table.
Assist Handles (Field Install)	3500287	Pair of Assist Handles and mounting hardware.

WARRANTY

For Brewer Warranty Information:

Registering your Brewer product is easy. Simply go to brewercompany.com/contact/warranty-registration, fill out the information fields and click send. By registering your product today, you are better safeguarding your investment in the future.

MANUALS IN OTHER LANGUAGES

Please visit Brewer Company's website brewercompany.com/resources to find this manual translated into additional languages.

NOTES