

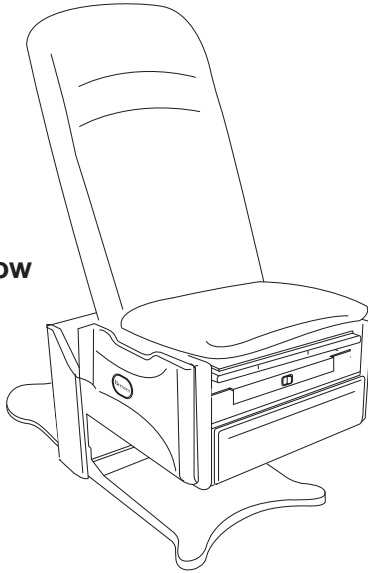

FLEX High-Low PLUS Power Exam Tables

Installation and Operation Manual

FLEX High-Low
Exam Table



FLEX High-Low
PLUS Exam Table

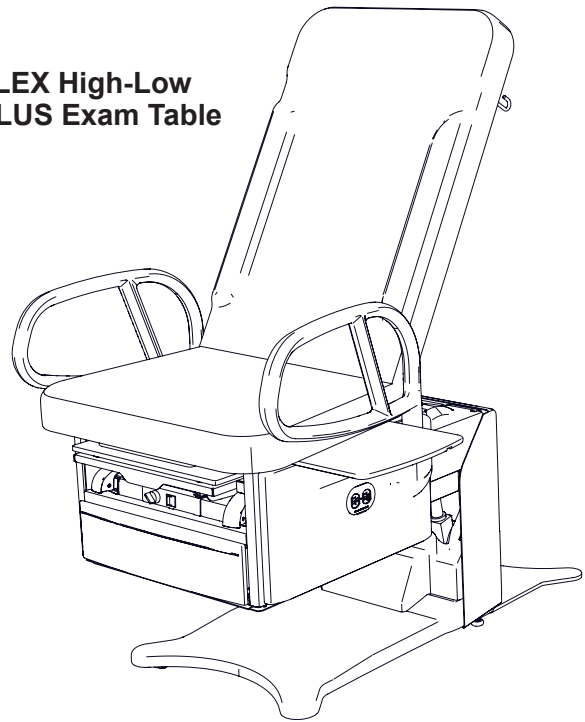

<i>Safety Information</i>	2	<i>Maintenance</i>	27
<i>Important Information</i>	3	<i>Service</i>	28
<i>Component Identification</i>	5	<i>Accessories</i>	29
<i>Specifications</i>	6	<i>Power Cord Options</i>	29
<i>Installation</i>	8	<i>Warranty</i>	30
<i>Operation</i>	15		

Registering your Brewer product is easy.

Simply go to brewercompany.com/contact/warranty-registration, fill out the information fields and click submit. By registering your product today, you are better safeguarding your investment in the future.



The Brewer Company, LLC
W165N5830 Ridgewood Dr., Suite 100
Menomonee Falls, WI 53051 USA

SAFETY INFORMATION

Safety Information



The primary concern of The Brewer Company is that the equipment is operated and maintained with the safety of the patient and healthcare staff in mind. To ensure safe and reliable operation:

- Read and understand all instructions in this manual before attempting to install or operate the unit.
- Ensure that appropriate personnel are informed on the manual contents. This is the responsibility of the purchaser.
- Ensure that this manual is located near the table, or if possible permanently affixed to the table.

Proper Disposal

- Follow local and state guidelines for proper disposal of product. Metal work can be recycled through licensed recycling facilities. For further assistance, please contact your dealer.
- Any serious incident that has occurred in relation to the device should be reported to the manufacturer and the competent authority of the Member State in which the user and/or patient is established.

Symbols

	Yellow triangle with black border and black symbol warns of a hazardous situation.
	Blue circle with white symbol requires mandatory action to avoid causing a hazardous situation.
	Red ring with diagonal bar and black symbol prohibits an action that may cause a hazardous situation.

Definitions

- **WARNING** indicates a hazardous situation which, if not avoided, could result in death or serious injury.
- **CAUTION** indicates a hazardous situation which, if not avoided, could result in minor or moderate injury.
- **NOTICE** indicates a situation not related to physical injury which, if not avoided, could result in equipment or property damage.



Refer to manual



Connect to ground (earth)



Disconnect from electrical outlet



Manufacturer



Date of Manufacture



Type B Applied Part



Medical Device



Shock hazard



Fall hazard



Explosion hazard



Fire hazard



Pinch hazard



Trip hazard



Backrest Lowering Hazard



Automatic Startup



Do not push



Do not sit



Do not step

IMPORTANT INFORMATION

General

Read and understand all operating instructions, safety information, and maintenance requirements contained in this manual prior to operating the table. Become familiar with all of the table functions before using it with a patient.

The Brewer Flex and Flex PLUS High-Low Exam Table Models 5700, 5800, 5700PLUS and 5800PLUS Series are designed to provide positioning and support of patients during general examinations conducted by qualified medical professionals.

The Brewer Flex and Flex PLUS High-Low Exam Tables are primarily used in examination rooms for general examinations and minor procedures. The wide variety of positions provided by the one or two powered motions, and slide-out leg support create safe and convenient patient positioning tables for use in the doctor's office.

Both tables are easily adjusted to a wide variety of positions using the convenient foot control provided with the tables. The table height can be adjusted from 18" to 38", and 17" to 37" on select models. The table seating surface on models 5701, 5801, 5701PLUS and 5801PLUS can be moved from the normal horizontal position to an angle of 5°. The backrest can be adjusted from a flat lying down position, to an 80° angle for seating.

The Brewer Access High-Low PLUS Exam Tables may have the SafeGlide™ Mobility Option. This allows medical professionals to move the table around the examination room more easily.

In addition to the controlled positions noted above, several manual adjustments are available:

- The SafeGlide leg support can be extended up to 18" for the patient prone position.
- Stirrups (standard on Models 5701, 5801, 5701PLUS and 5801PLUS) - may be manually extended through infinite positions and four lateral positions.
- A removable treatment pan is built-in underneath the leg extension pad for use during examinations.
- A storage drawer at the front of the table may be used for supplies.

Optional Features

- Stirrups (optional on Models 5700, 5800, 5700PLUS and 5800PLUS) - may be manually extended through infinite positions and four lateral positions.
- Patient assist handles attached to each side of the table may be rotated out of position or removed for improved access to the patient.
- A pass-through work surface, stored under the seat, may be pulled out from either side of the table. Not compatible with "PLUS-17" models.

IMPORTANT INFORMATION (CONTINUED)

Service

If you require assistance with the installation or operation of your Brewer Table, call the Brewer Customer Experience Department at **1-800-558-8777**. Our trained staff will attempt to assist you in correcting the problem directly over the phone. If service is required, a factory authorized technician may be sent to your location.

Please fill in the following information for use when calling The Brewer Company or your distributor with questions regarding your unit. See Figure 1 for model and UDI number location.

Date of Purchase _____

UDI Number _____

Model Number _____

Authorized Dealer Name _____

Dealer Phone Number _____

Dealer Address _____

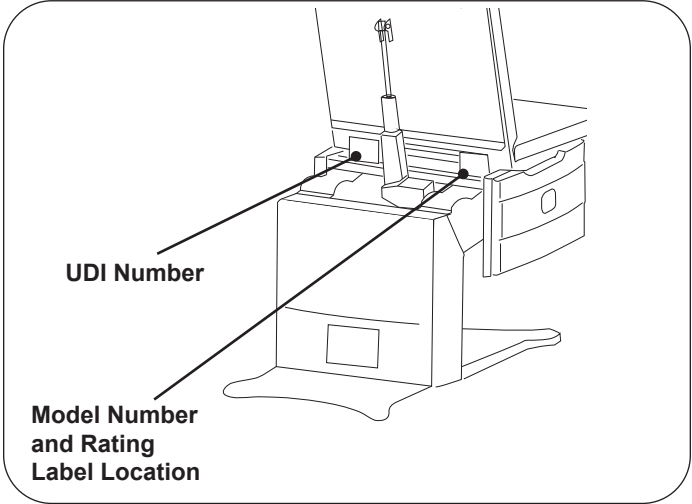

Figure 1. UDI Number, Model Number and Rating Label Locations

COMPONENT IDENTIFICATION

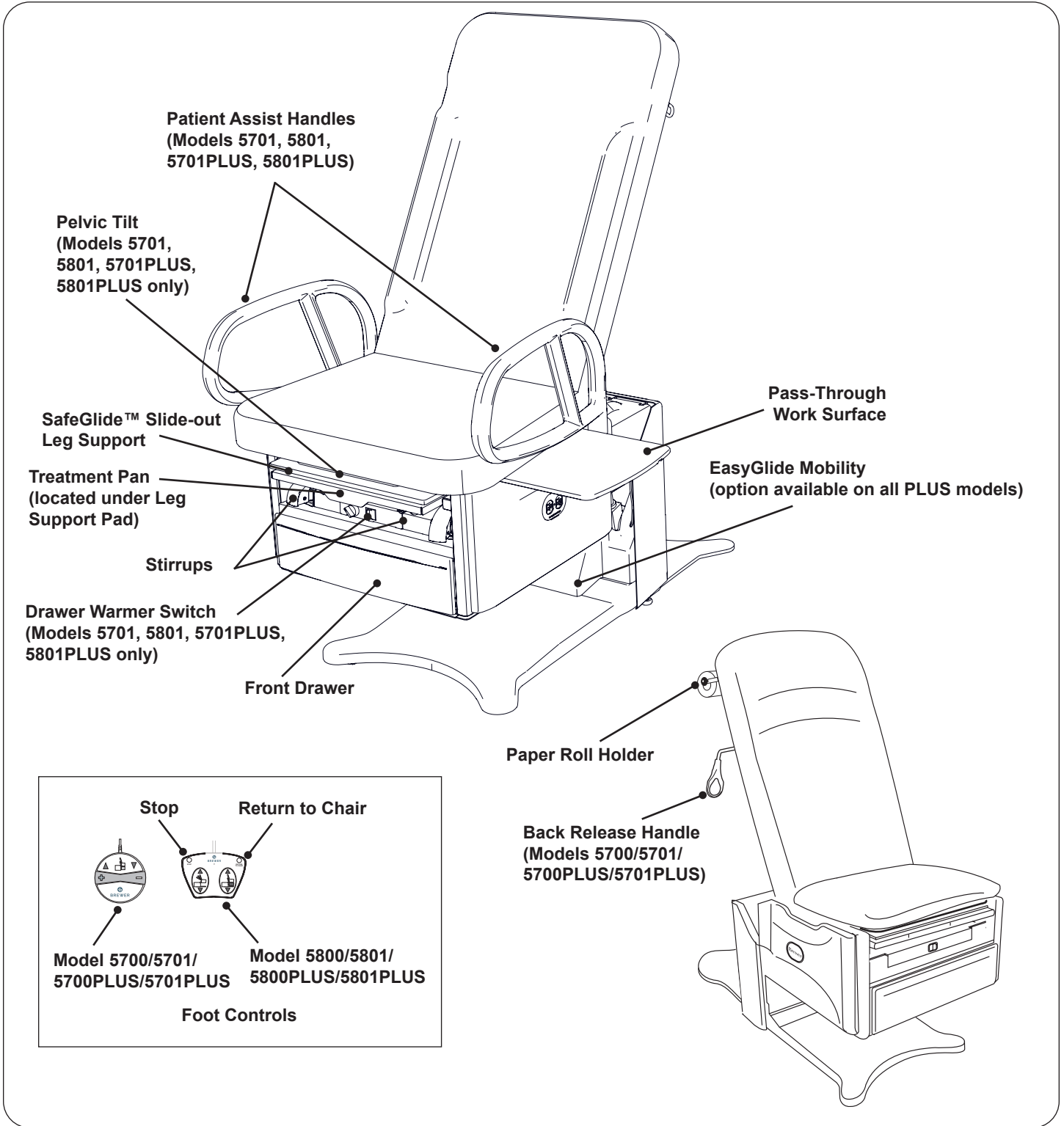

Figure 2. Component Overview

SPECIFICATIONS

Weight of Table

- Models 5700, 5701, 5800, 5801.....315 lbs.
- Models 5700PLUS, 5701PLUS, 5800PLUS, 5801PLUS.....330 lbs.

Load Rating (maximum)

- Seat/Back 5700/5701/5800/5801/5700PLUS/5701PLUS/5800PLUS/5801PLUS700 lbs.
- Leg Support.....50 lbs.
- Pass-Through Work Surface (optional).....15 lbs.
- Patient Assist Handles (optional)100 lbs.

Back Section Range 0° (horizontal) to 80° ±5°

Table Top Height Range 18 ± 0.5 in. to 38 ± 1.0 in.

- "PLUS-17" Table Top Height Range.....17 ± 0.25 in. to 37± 1.0 in.

Pelvic Tilt Height Range

- **Models 5701, 5801, 5701PLUS & 5801PLUS Only** 0° (horizontal) to 6° (up)

Upholstery Dimensions

- Upholstered Top24 to 28 in. wide x 60 in. long
- Upholstered Leg Support18 in. long x 18 in. wide
- Overall Length.....60 in. long
- With Leg Support Extended78 in. long

Electrical Requirements

- **5700/5800/5700PLUS/5800PLUS models:** 115 VAC nominal, 60 HZ, 6.0 amps max.
- **5701/5801/5701PLUS/5801PLUS w/Outlet models:** 115 VAC nominal, 60 HZ, 6.0 amps max.
- **5700-230/5800-230 models:** 230 VAC nominal, 60/50 HZ, 3.0 amps max.

Fuse Rating

- Option/Warmer & Outlet Fuse Rating.....250V/1.0 Amp
- Outlet Max Load2.0 Amp

Duty Cycle (10%)

.....2 minutes on/18 minutes off (motor run time)

Power Cord

- Length Extends 70 in. minimum from table
- Type (5700, 5701, 5800, 5801) Detachable
- Type (5700PLUS, 5701PLUS, 5800PLUS, 5801PLUS, 5700-230, 5800-230) Detachable
- Conductors18 AWG/3 Conductor
- Grade Hospital Grade Plug

Type of protection against electrical shock

- Model 5700/5800/5700PLUS, & 5800PLUS Class 2 Double Insulated
- Models 5701, 5801, 5701PLUS & 5801PLUS Class 2 Double Insulated
- Patient applied parts (all models)..... Type B

Type of protection against ingress

of water.....Foot Control IPX1

Paper Roll Sizes

- Regular.....18 in. x 3.5 in.
- Long21 in. x 3.5 in.

Certifications* UL60601-1;CAN-CSA C22.2 No. 601.1

Operating Conditions

- Temperature Range 65°F to 185°F
- Humidity Range.....10% to 90%

Transportation and Storage

- Temperature Range-20°F to 150°F
- Humidity Range.....10% to 90%

Drawer Warmer

- **120V models** 120 VAC, 60W, 0.5 Amps

**Warmed temperature 10-15°F above ambient*



*Classified in the United States and Canada per the standards listed above.

230V models have not been evaluated

SPECIFICATIONS (CONTINUED)**WARNING: Explosion/Fire Hazard**

Do not use this table in an explosive or oxygen rich atmosphere. Doing so may result in serious personal injury or death.

**WARNING: Shock Hazard**

When performing cauterization or similar treatment, the patient must be insulated from the metal portions of the table by non-conductive material. Failure to do so may result in electrical shock.

NOTICE: CERTIFICATIONS

This product has been evaluated with respect to electrical shock, fire, and mechanical hazards only in accordance with UL60601-1; CAN/CSA C22.2 No. 601.1

NOTICE: Electromagnetic Interference (EMI)

This product is designed and built to minimize electromagnetic interference with other devices; however, if interference is noticed between another device and this product, remove the interfering device from the room or plug this product into an isolated circuit.

INSTALLATION

NOTICE: Inspect Carton and Contents

Inspect all boxes and contents for damage. Report any damage to the carrier immediately.

NOTICE: No Sharp Tools

To avoid damaging the table's upholstery or painted surfaces, **DO NOT** use a knife or other sharp object to open the packaging.

Overview

Perform the following sequence, in order, when setting up the table:

- Uncrating the Table
- Leveling the Table
- Adjusting Rear Base Extension
- Installing Foot Control
- Installing Power Cord
- Installing Patient Assist Handles (Optional)

NOTICE: Optimum Table Performance

For optimum table performance, allow the table to reach room temperature before operating.

Uncrating

Tools Required

- Drill Driver
- 7/16" socket bit, or 7/16" wrench
- 9/16" wrench
- #2 Phillips bit
- Side Cutter
- Furniture Dolly

Hardware Required

- None

Instruction

1. Pull carton from staples all around the bottom of the container where it is attached to the pallet. Use pliers to remove any staples that are still in the carton.



Figure 3. Carton Removal

2. Carton is easiest to remove by lifting on end of carton with "Do Not Lift" imprint.

NOTE: Your table will have protective stretch wrap and microfoam.



CAUTION

Do not plug power into table prior to removal of all packaging materials.



CAUTION

Damage may occur if staples are left in the carton.

INSTALLATION (CONTINUED)

3. Remove stretch wrap surrounding table.
4. Remove the 2-4 steel shipping brackets securing the table to the pallet (Figure 4). The brackets hook onto the table levelers to hold the table securely to the pallet. Remove the 2 bolts from each bracket using a 7/16" socket or wrench. Take care not to scratch the unit when using the driver or turning the wrench. Remove brackets from levelers once bolts are removed.

NOTE: Verify all brackets are removed. Failure to remove a shipping bracket may cause damage to the facility flooring.

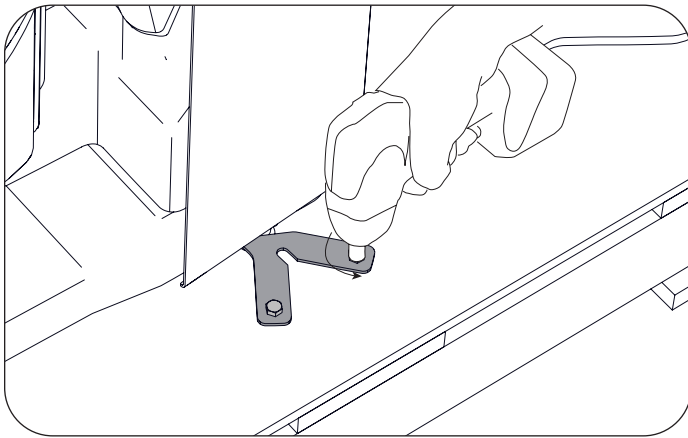

Figure 4. Remove Shipping Brackets

5. On the Flex PLUS tables, remove the two bolts and metal bracket holding the table frame to the pallet (Figure 5).

NOTICE

Not following uncrating procedure could cause damage to mobility option components and nearby property.



Figure 5. Flex PLUS Bracket

6. Remove the 2 screws attaching the spacers on either side of the wooden U-shaped brace located under the front corners of the cabinet (Figure 6). Remove the 2 screws attaching the U-shaped brace to the pallet (Figure 6).

NOTICE: Patient Assist Handle

If your table was purchased with the Patient Assist Handle option, remove the box from the back of the pallet.

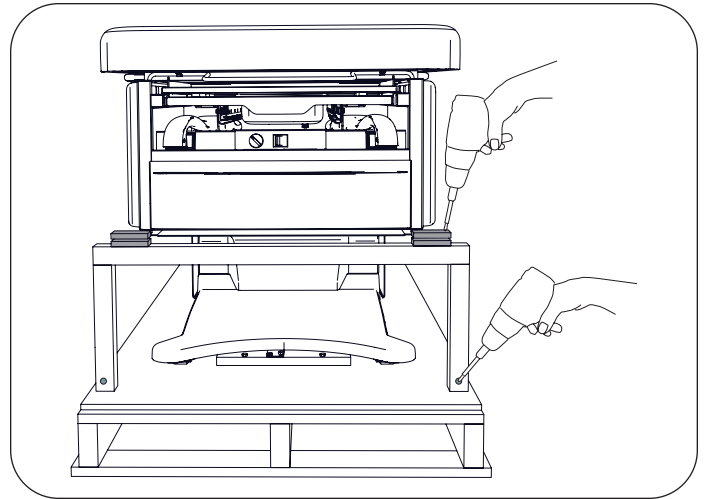

Figure 6. Remove Spacer and U-Brace Screws

7. Cut the shipping strap, and discard strap and foam tube (Figure 7).

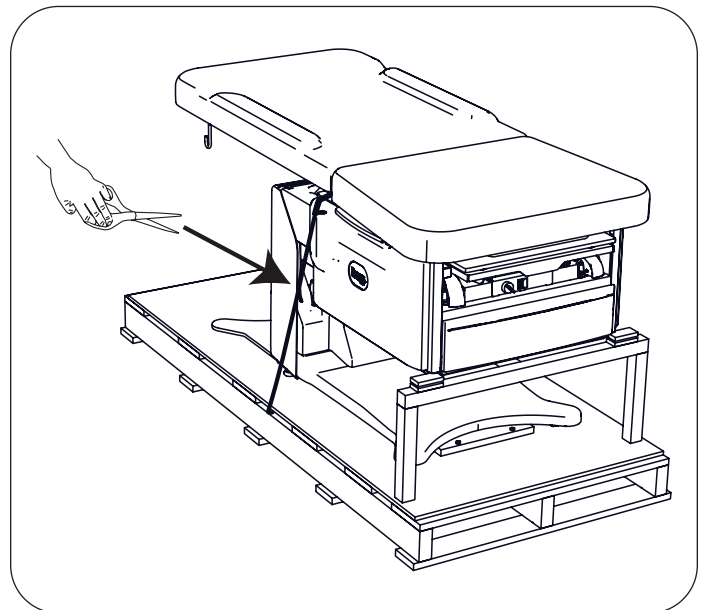

Figure 7. Cut Shipping Strap

INSTALLATION (CONTINUED)

- Make sure all shipping materials (except for wooden brace and spacers) and packing foam are removed from the table, pallet and surrounding area.

NOTE: In order to remove the table from the pallet, you must first power it up and elevate the seat from it's shipping position.

NOTICE: Avoid Self Activation Damage

Plugging table into receptacle prior to the removal of all packaging materials, may cause damage if self activation occurs.

- Remove the foot control and power cord from the front drawer after packing materials have been removed.
- Insert the foot control cord into the receptacle at the bottom of the rear panel (Figure 8). Make sure the tab on the plug is aligned with the slot in the receptacle.

NOTE: The plug may appear to be fully inserted and yet have some distance to go. Wiggle the foot control plug while pushing it in firmly to ensure that it is fully seated (Figure 9).

- Plug the power cord into the receptacle at the bottom of the rear panel (Figure 8). Plug the power cord into a 115 Volt or 230 Volt receptacle, depending on your configuration.

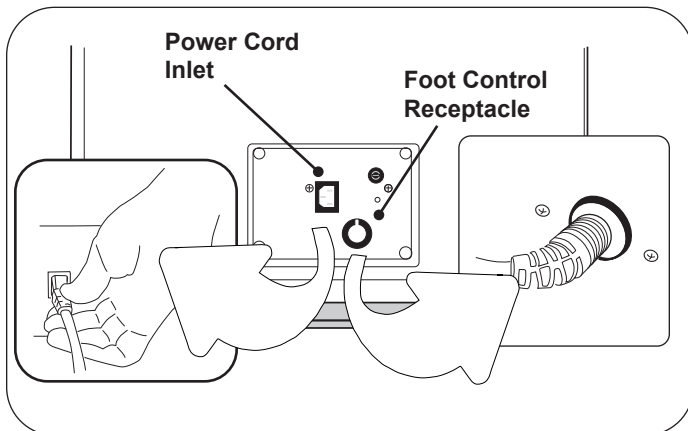

Figure 8. Power Cord and Foot Control Plug-ins

NOTICE: Confirm Voltage and Plug Type

See Specifications page for electrical rating of this unit.



CAUTION: Use Grounding Plug

To avoid risk of electric shock, connect this equipment to a supply mains with protective earth. Plug the grounding plug on the table power cord into a matching grounded, non-isolated, correctly polarized receptacle.

WARNING: Area Not Clear Hazard

Before initiating movement keep personnel and equipment clear of table to avoid personal injury or damage to the equipment.

Foot Control Plug Even with or Above Receptacle Rim



Foot Control Plug not Fully Inserted

Foot Control Plug Below Receptacle Rim

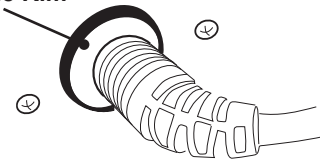

Foot Control Plug Fully Inserted

Figure 9. Foot Control Properly Pugged In

INSTALLATION (CONTINUED)

12. Press “Lift Up” on the foot control to raise the seat approximately 1" (Figure 10). Remove the wooden U-brace and shipping spacers at the front of the table.

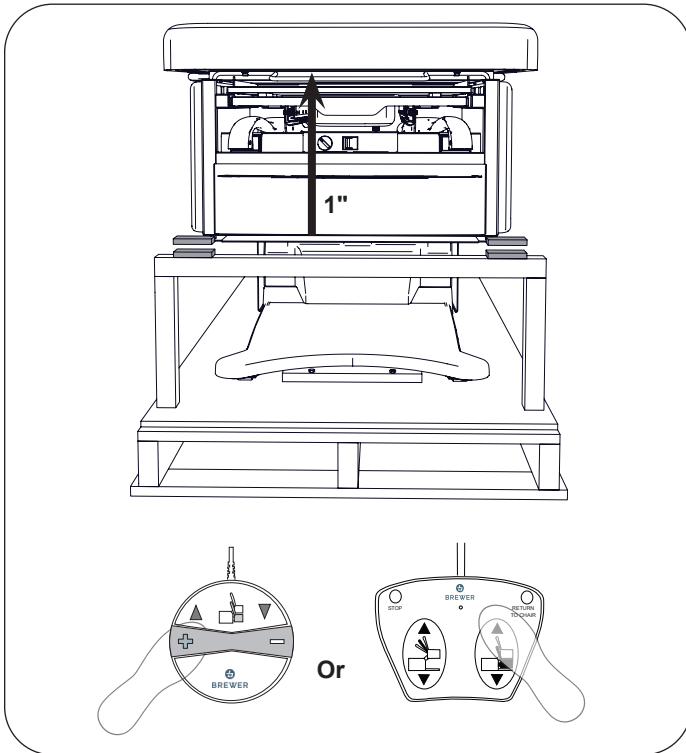

Figure 10. Raise Seat off of Brace

13. Raise the backrest to its full up position (Figure 11).

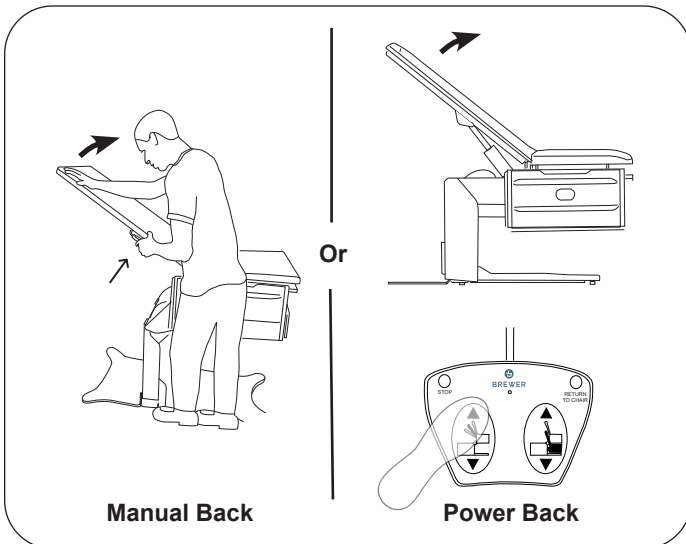

Figure 11. Raise Backrest

14. Unplug foot control and power cord and place into front storage drawer (Figure 12).

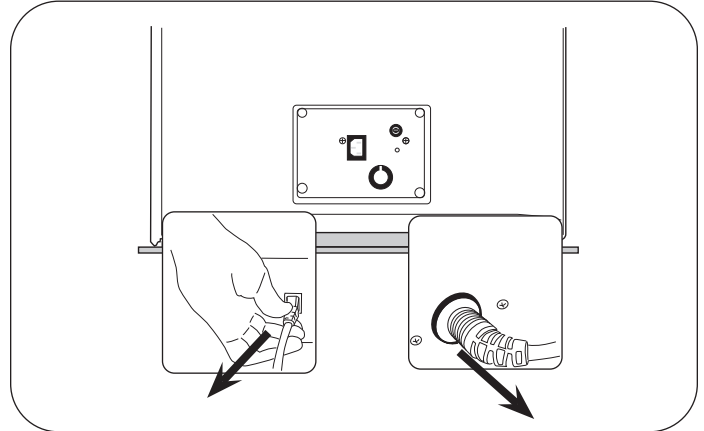

Figure 12. Unplug Foot Control and Power Cords

NOTICE: Avoid Pelvic Tilt and Upholstery Damage
Do not lift or move table by pulling up on the seat upholstery (Figure 13). Lifting by the seat will damage the pelvic tilt mechanism (if equipped) and may damage the upholstery.



Figure 13. DO NOT Lift by Upholstery

NOTICE: Avoid Backrest Actuator and Upholstery Damage
Never push forward on the backrest to move table. Pushing on the backrest will cause backrest actuator damage and may cause upholstery damage (Figure 14).



Figure 14. DO NOT Push on Backrest

INSTALLATION (CONTINUED)

NOTICE: Avoid Stirrup Damage

Do not lift or move table by using the stirrups as a hand hold. Lifting or moving table by stirrups can damage the internal indexer housing (Figure 15).

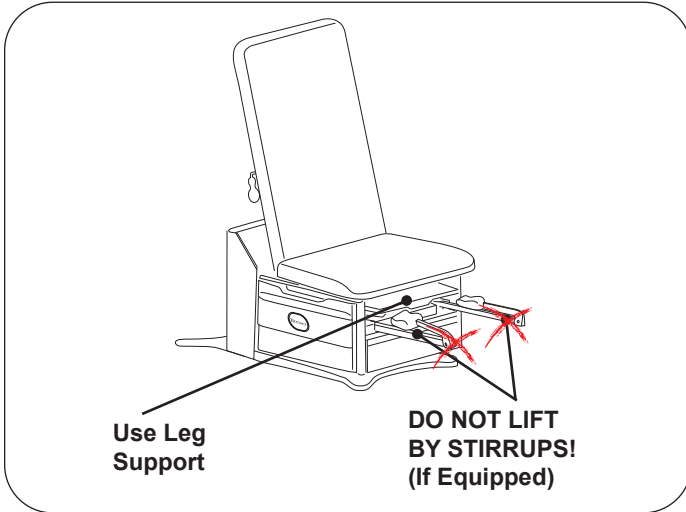

Figure 15. DO NOT Lift by Stirrups

NOTICE

Table weighs approximately 330 lbs.

- Use leg support to slide table partially off of pallet. Stop when there is sufficient room to place a furniture dolly beneath base of table. Finish pulling table onto furniture dolly (Figure 16).

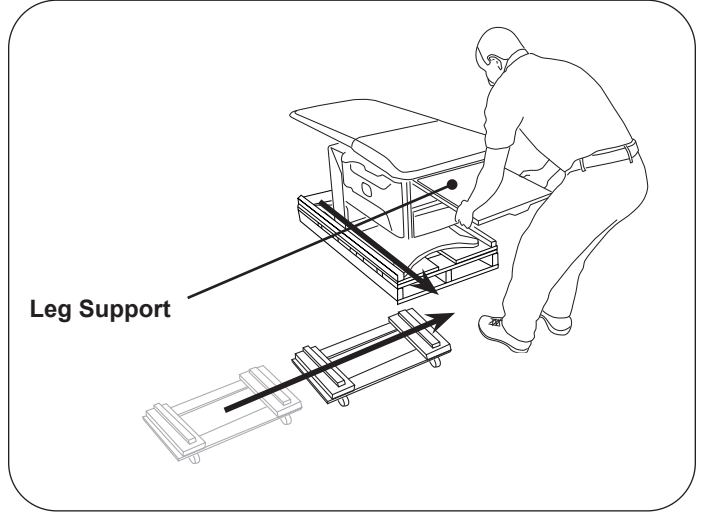

Figure 16. Slide Table off of Pallet

- Move table to its final location. Lift off of furniture dolly and set down into position. Do not push or pull sideways on Leg Support when positioning table. (Figure 17).



Figure 17. Do Not Move by Fully Extended Leg Support

INSTALLATION (CONTINUED)

Leveling the Table

Tools Required

- None

Hardware Required

- None

Instruction

A leveling screw pad (Figure 18) is located in two to four places under the table's base. Adjust the leveling pads to achieve a solid, level installation.

Before using the EasyGlide Mobility Option on PLUS models, ensure that the rear levelers are set so that the mobility option lifts higher than the levelers. Do this by activating the mobility option and checking for clearance under the levelers.

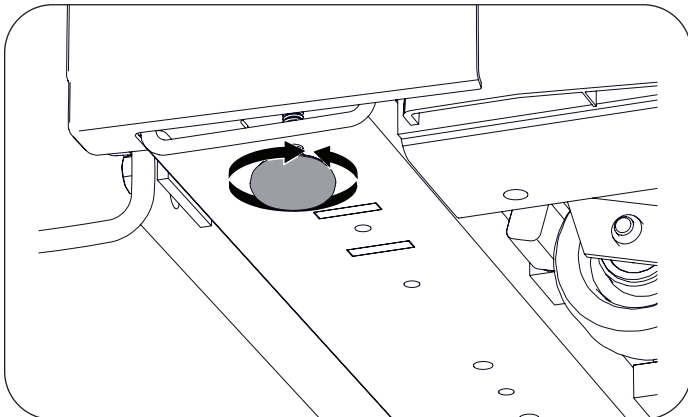

Figure 18. Leveling Screw Pad (located under table)

NOTICE: Prevent Leveler Damage

Levelers must remain in the table and be fully engaged a minimum of (3) turns. If levelers are not fully engaged in the base, damage to the threading in the base and/or leveler can occur.

NOTICE: Prevent Floor Damage and Unwanted Table Movement

Make sure the caps are present on all levelers. Missing caps may cause less than optimal movement of the table or damage to the facility flooring.

Adjusting the Rear Base Extension

After leveling the table, the Rear Base Extension should be brought into contact with the floor (Figure 19). If EasyGlide option is installed, ensure it is not deployed.

1. Loosen the two Rear Base Extension adjusting screws.
2. Lower plate until it contacts the floor.
3. Tighten the two Rear Base Extension adjusting screws.

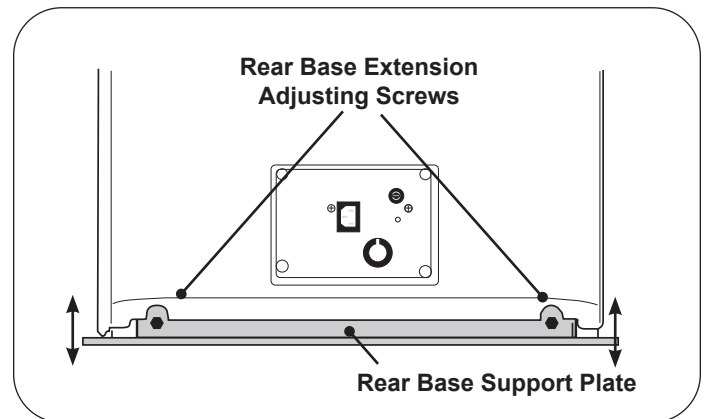

Figure 19. Adjusting the Rear Base Extension

INSTALLATION (CONTINUED)

Installing the Power Cord

1. Remove the power cord from the front drawer.
2. Insert the female plug end of the power cord into the receptacle on the table. Make sure the plug is fully seated (Figure 20).

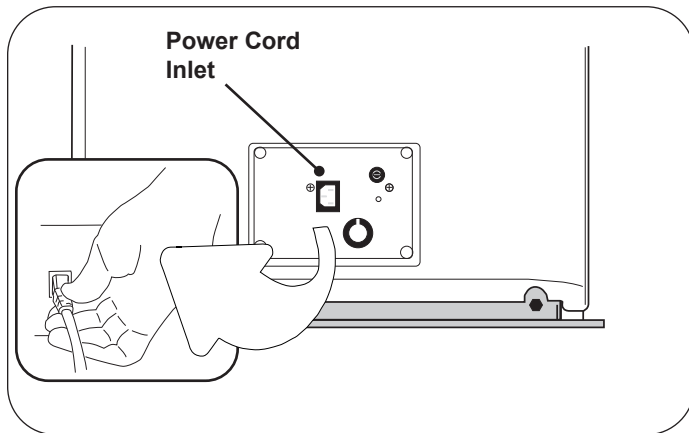

Figure 20. Power Cord Inlet

NOTICE: Confirm Voltage and Plug Type

See Specifications Page for electrical rating of this unit. The three-pronged grounding plug on the table power cord must be plugged into a matching three-pronged, grounded, non-isolated, correctly polarized 115 VAC or 230 VAC receptacle.

Installing the Foot Control

1. Remove the foot control from the front drawer.
2. Insert the male plug of the foot control cord into the receptacle on the table (Figure 21). Make sure the plug is fully seated. See (Figure 9) for proper insertion of the foot control plug. Failure to properly insert the foot control plug can cause some functions to not operate properly.

NOTICE: Avoid Foot Control Damage

The foot control is moisture resistant and runs on low voltage, eliminating shock hazards. However, to avoid temporary or permanent damage to the foot control, do not immerse in water or liquids.

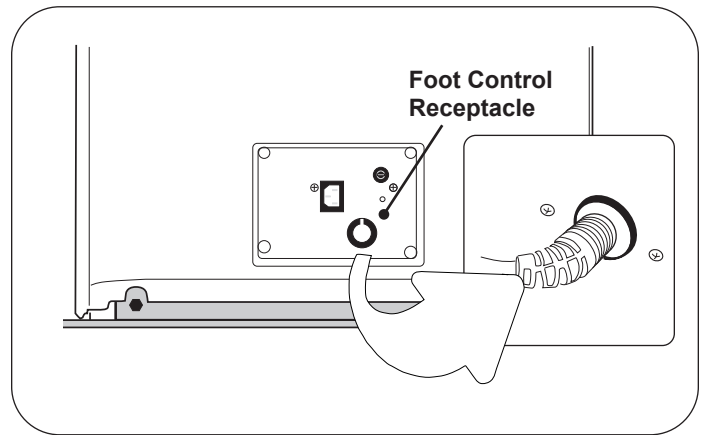

Figure 21. Foot Control Receptacles

Installing Patient Assist Handles (Optional)

1. Remove Patient Assist Handles from the carton banded to the pallet.
2. Patient Assist Handles are interchangeable and may be installed on either side.
3. Align pin on Patient Assist Handle shaft with mating slot on side of table. See Figure 22.

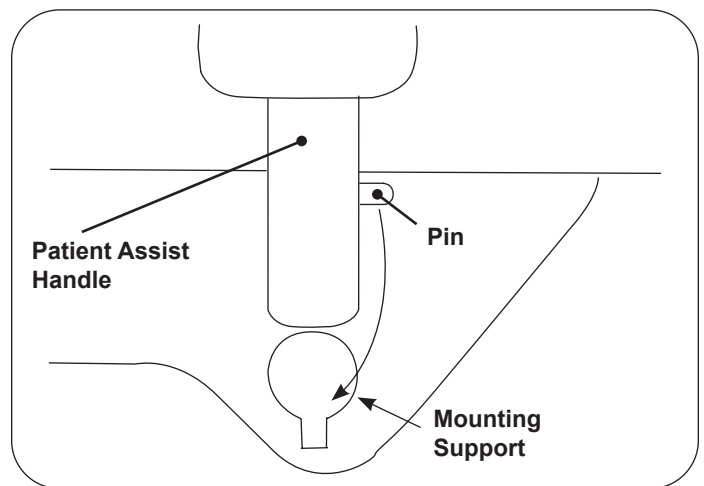

Figure 22. Patient Assist Handle

4. Push Patient Assist Handle all the way down and rotate to front of table.
5. Push Patient Assist Handle down until it engages to prevent left or right movement.





WARNING: Shock Hazard

After installing or moving table, make sure there are no damaged or exposed wires that could result in electrical shock.

OPERATION

Before Use

	<p>CAUTION: Read this Manual</p> <p>Read this manual before use of the Brewer FLEX High-Low or High-Low PLUS Examination Table.</p>
-----------------------------------------------------------------------------------	--------------------------------------------------------------------------------------------------------------------------------------------

	<p>WARNING: Explosion/Fire Hazard</p> <p>Do not use this table in an explosive or oxygen rich atmosphere. Doing so may result in serious personal injury or death.</p>
-----------------------------------------------------------------------------------	-------------------------------------------------------------------------------------------------------------------------------------------------------------------------------

	<p>WARNING: Shock Hazard</p> <p>When performing cauterization or similar treatment, the patient must be insulated from the metal portions of the table by non-conductive material. Failure to do so may result in electrical shock.</p>
-----------------------------------------------------------------------------------	------------------------------------------------------------------------------------------------------------------------------------------------------------------------------------------------------------------------------------------------

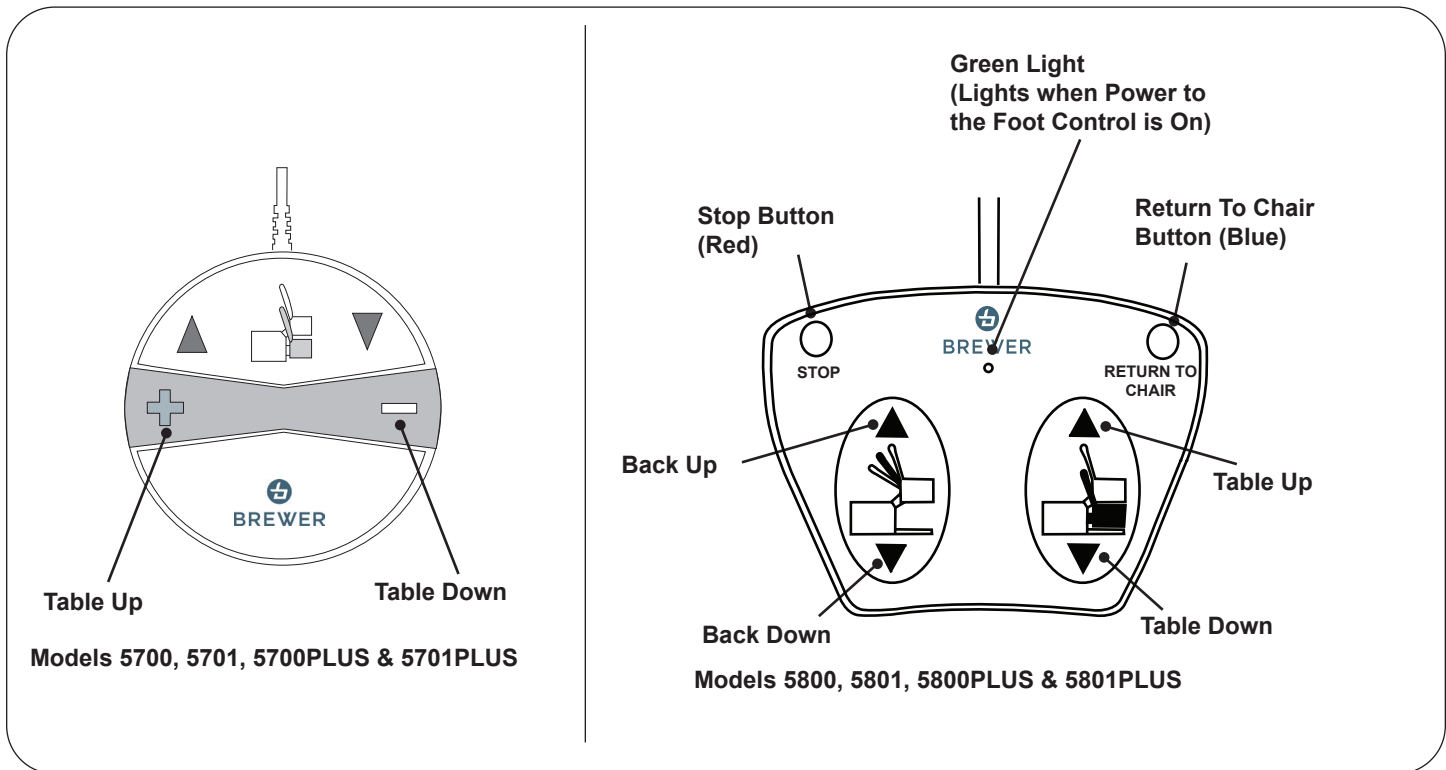

Figure 23. Foot Controls

OPERATION (CONTINUED)

Models 5700, 5701, 5700PLUS & 5701PLUS

Models 5700, 5701, 5700PLUS and 5701PLUS are equipped with a single pedal foot control that raises and lowers the seat.

Models 5800, 5801, 5800PLUS & 5801PLUS

Models 5800, 5801, 5800PLUS & 5801PLUS are equipped with a dual pedal foot control that controls the raising/lowering of the seat, and raising/lowering of the seat back. In addition, the foot control features the following:

- **Return to Chair:** When pressed, the table automatically returns to the low chair position. The seat back will rise to the full up position and the table will lower to the full down position and stop. To stop the automatic movement, press the Red Stop Button, or depress any pedal on the foot control.
- **Stop:** When pressed, stops the Return to Chair function.
- **Green Light:** Indicates that there is power to the foot control.

NOTICE: Unintended Operation

To avoid unintended operation, keep foreign objects away from foot control. Be sure foot control is not positioned below the front of the table.

NOTICE: Models 5700PLUS, 5701PLUS, 5800PLUS & 5801PLUS

For optimal operation, do not run Return to Chair feature while engaging or disengaging the EasyGlide mobility option.

NOTICE: Unattended Return to Chair Operation

Remain with and observe patient during Return to Chair operation. Return to Chair feature may need to be momentarily interrupted for patient to readjust themselves or for obstacles to be removed before resuming motion. Press the Return to Chair button to resume motion only when patient has situated themselves or obstacles have been removed.

Seat and Backrest Safety Switches

Seat Switch

All models are equipped with switches on the seat bottom (Figure 24) which automatically stop the lowering function of the seat if the seat bottom plate comes into contact with an object as the seat is lowering. To continue lowering the seat, press the "TABLE UP" pedal (Figure 23), clear the obstruction, and continue lowering the seat.

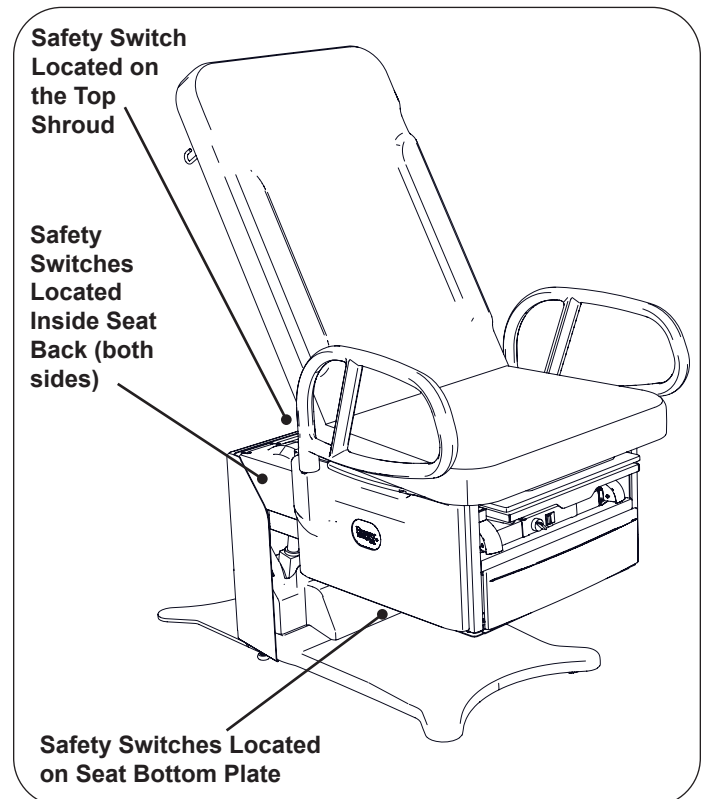

Figure 24. Seat and Backrest Safety Switches

OPERATION (CONTINUED)

Backrest Switch

All models are equipped with a switch on the top shroud (Figure 24) which automatically stops the lowering function of the seat and back if the switch is contacted by the backrest. To continue lowering the seat:

- **Models 5700, 5701, 5700PLUS & 5701PLUS** Raise the backrest manually to clear the switch. When clear of the switch, continue lowering the seat.
- **Models 5800, 5801, 5800PLUS & 5801PLUS** Depress the "BACK UP" pedal (Figure 23) to clear the switch. When clear of the switch, continue lowering the seat.

SafeGlide™ Leg Support

The leg support is located under the seat cushion (Figure 25). It can be extended 18" for the patient prone position. Pull leg support out to the fully extended position. To return the leg support to its stored position push the leg extension in.

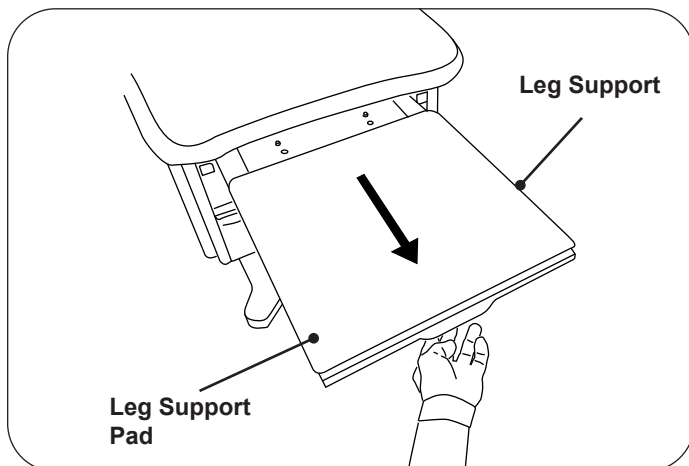

Figure 25. Leg Support Pull Out



WARNING: Fall Hazard

Do not allow patient to sit on the leg extension portion of the table. Doing so may result in serious personal injury or death.

Leg Support Pad

The leg support pad can be slid beneath the seat with the leg support extended for easy access to the treatment pan (Figure 26). Pushing the leg support back in will allow the glides on the pad to drop into slots. The pad will once again come out with the leg support the next time it is pulled out.

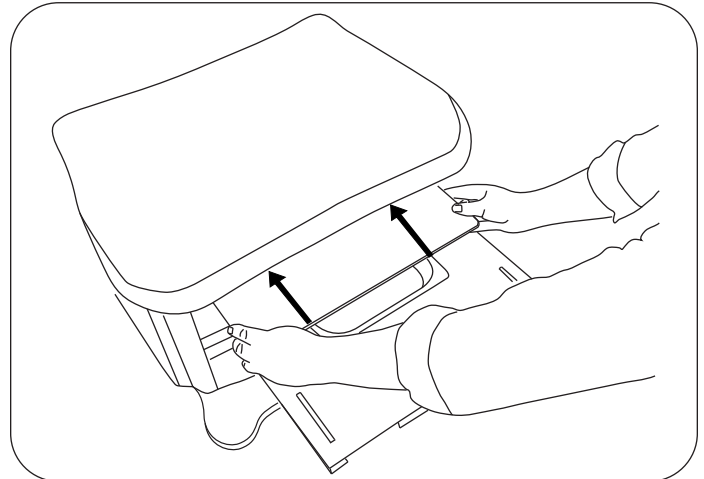

Figure 26. Slide Foot Pad Back

Treatment Pan

A removable treatment pan is built-in underneath the leg support pad for use during examination. Pull the leg support fully out and remove the leg support pad or slide it back under the seat to access the pan (Figure 27). Remove the treatment pan for cleaning.

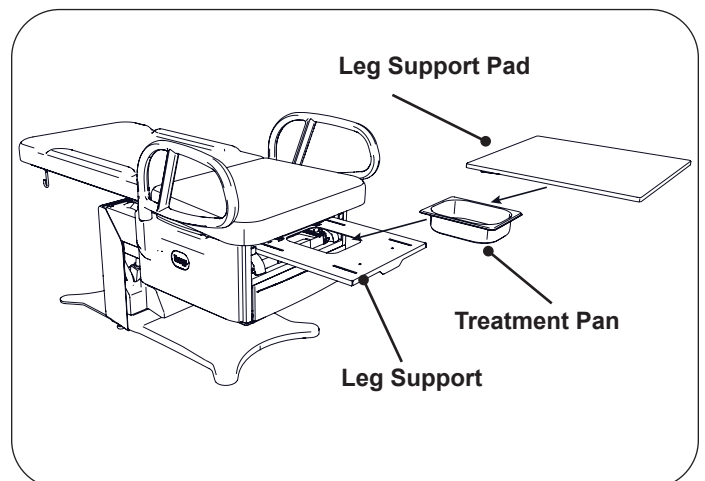

Figure 27. Treatment Pan

OPERATION (CONTINUED)

Front Drawer

A storage drawer for supplies is located at the front of the table. Models 5701, 5801, 5701PLUS and 5801PLUS are equipped with a drawer warmer that is turned on by a switch located above the drawer (Figure 28).

NOTE: The warmer element is located above the drawer and applies radiant heat to the drawer contents. Items closer to the element will be warmer than items at the bottom of the drawer. Avoid stacking instruments or allowing instruments to tip and contact the element.

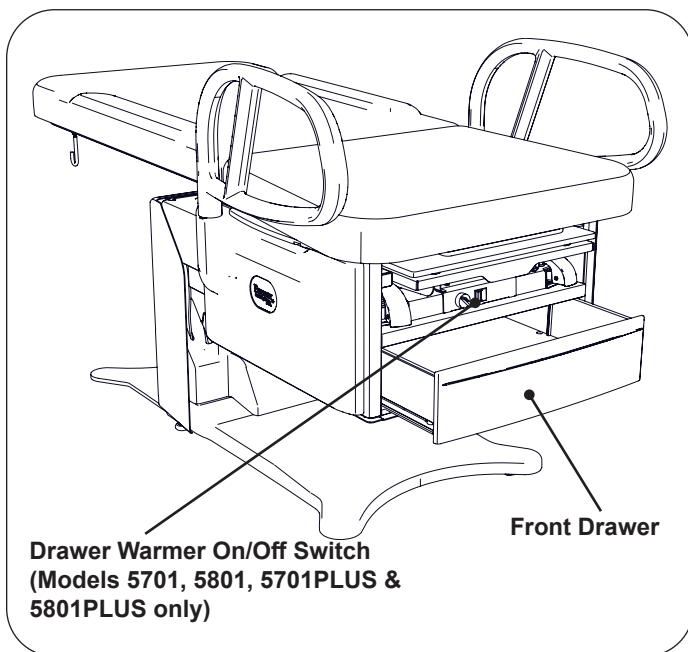

Figure 28. Drawer Warmer Switch and Front Drawer

Paper Roll Holder

To change a paper roll, remove old paper roll tube, place the paper holder rod into the paper roll tube, and place into paper roll holder "J-Hooks" located on the rear of the seat back (Figure 29). Pull the end of the roll over the top of the seat back and place in the desired position.

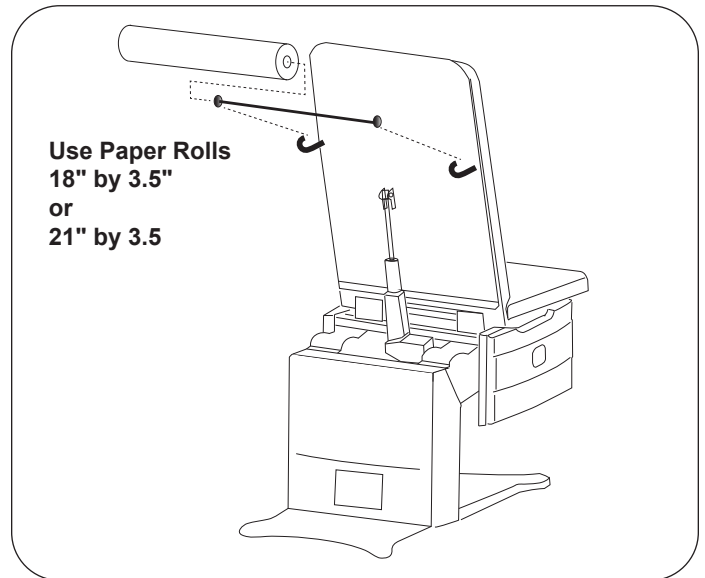

Figure 29. Paper Roll Installation

OPERATION (CONTINUED)

Pass-Through Work Surface (Optional)

A pass-through work surface, stored under the seat (Figure 30), may be pulled out from either side of the table. Grasp the edge of the work surface and pull until it is fully extended. Push it fully in to stow after use.

NOTE: Pass-through work surface is not compatible with "PLUS-17" models.



WARNING: Fall Hazard

The work surface is rated for 15 lbs. and is not intended for use as a seat. Sitting on work surface could cause it to bend or break or cause the table to tip creating a fall hazard leading to injury or death.

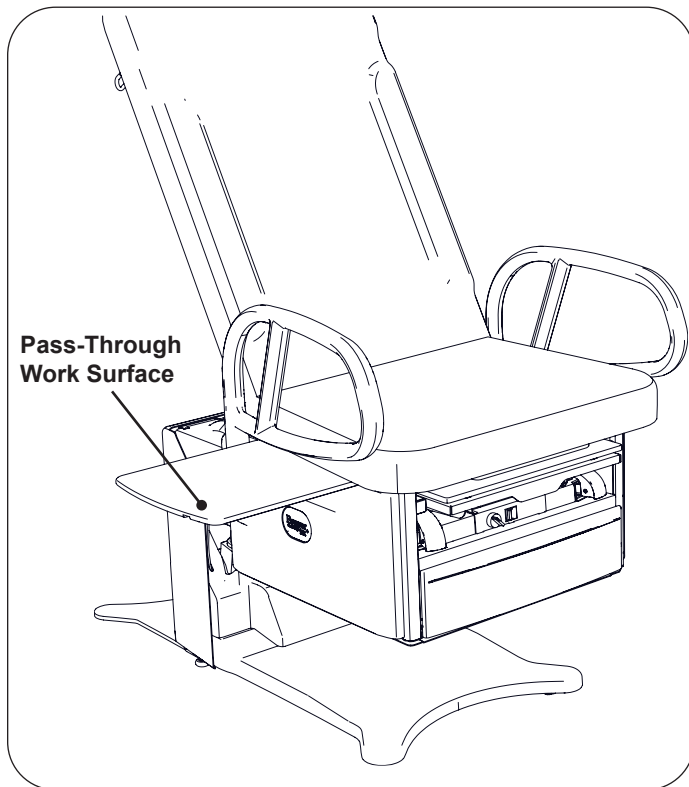

Figure 30. Pass-Through Work Surface

Removing the Work Surface for Cleaning

1. Push work surface in to reveal a white plastic screw.
2. Remove the white plastic screw (Figure 31).
3. Pull the work surface toward you and remove it.
4. Reinsert screw after replacing work surface.

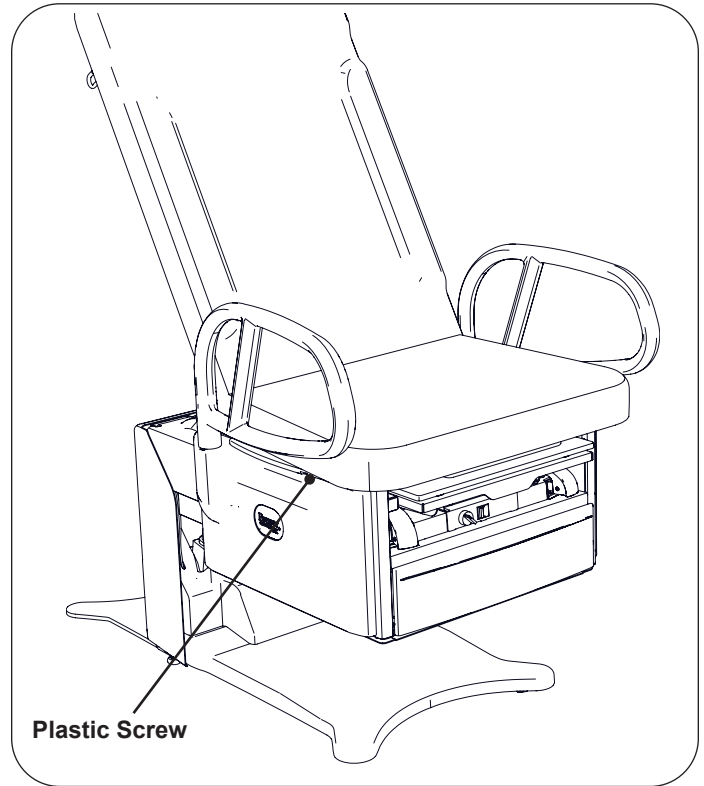

Figure 31. Location of White Plastic Stop Screw

OPERATION (CONTINUED)

Adjustable Stirrups

(Standard on Models 5701, 5801, 5701PLUS and 5801PLUS)

(Optional on Models 5700, 5800, 5700PLUS and 5800PLUS)

Operating the Stirrups

1. To operate the stirrups, grasp end of stirrup and pull straight out of the table (Figure 33). Lift up slightly while sliding the stirrup out.

NOTE: Applying downward pressure when pulling stirrup from table may make it difficult to move. Resistance is normal and is part of the stirrup friction locking mechanism.

2. Unfold stirrup upward to the fully open position.
3. Adjust the stirrup to the desired length by sliding it in or out.

Stirrup Lateral Adjustment

1. Lift end of stirrup slightly and then pivot outward to desired position.
2. When the desired position is achieved, lower the stirrup to engage the lateral locking mechanism (Figure 32 and Figure 33).
3. Check that lateral locking mechanism is engaged by attempting to move stirrup assembly side-to-side without lifting on the stirrup end.

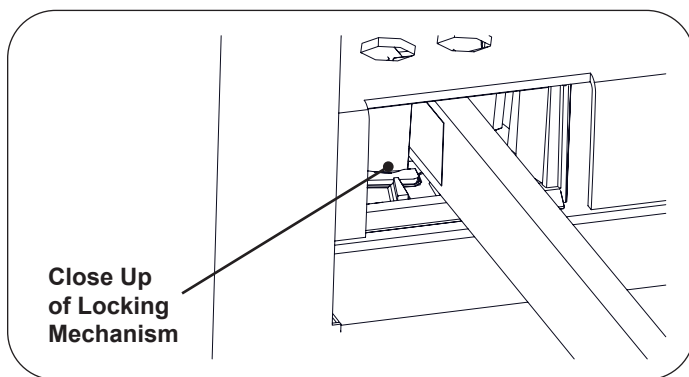

Figure 32. Stirrup Locking Mechanism

Storing the Stirrups

1. To store the stirrups in the table, grasp end of stirrup and pull straight out to its full extension.
2. Fold stirrup down against bar, then pivot it to the inner most lateral position and slide it back into the stowed position.

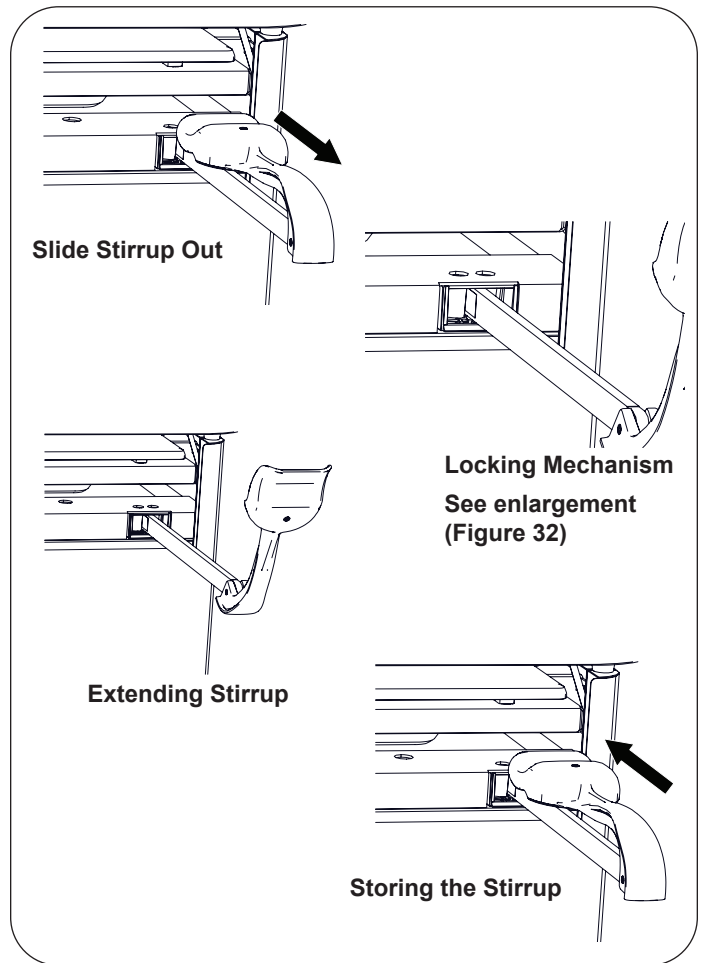

Figure 33. Stirrups

NOTICE: Use Stirrup Only as Designed

Do not use any part of the stirrup for attachment of any device. Warranty will be voided.



OPERATION (CONTINUED)

Patient Assist Handles (Optional)

In the forward (normal use) position, the Patient Assist Handles lock into place preventing left or right rotation.

The Patient Assist Handles can be rotated to the side or toward the back of the table for improved access and stability of the patient. Pull up on the Patient Assist Handle and rotate to the desired position. The Patient Assist Handle locks in the front, side and rear positions (Figure 34).

The Patient Assist Handle can be removed from the table by pulling up on the Patient Assist Handle, rotating it to the 90° position, and then lifting it out of its holder.

NOTICE: Patient Assist Handles Versions

Some Patient Assist Handles only lock in (2) positions: front and side.

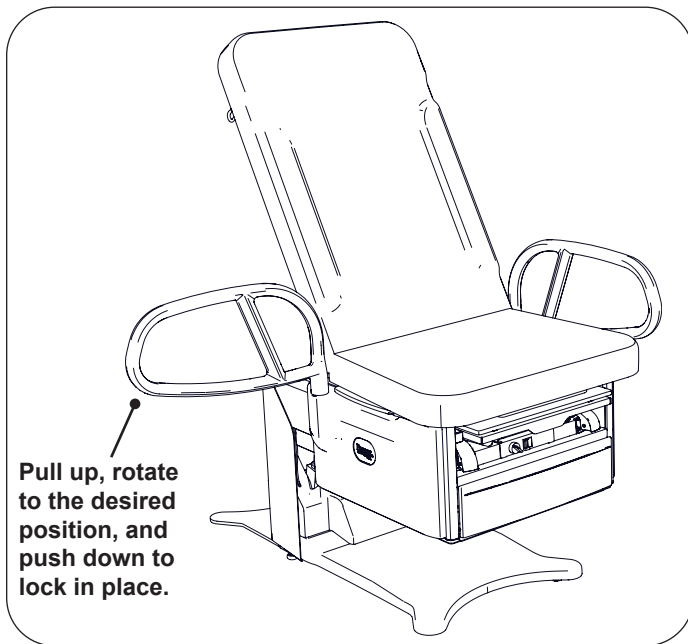

Figure 34. Patient Assist Handles Adjustment

Table Height

The table can be adjusted to any height between 18" to 38", or 17" to 37" for "PLUS 17" models (Figure 35).

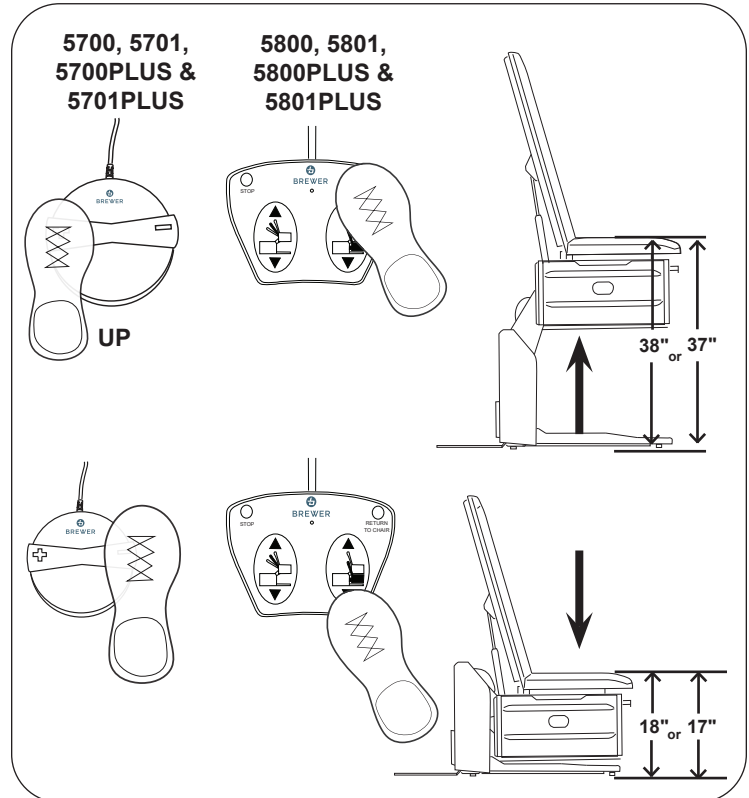

Figure 35. Table Height Positioning

1. To raise the table, depress and hold the Table Up pedal until the desired height is achieved, then release the pedal.
2. To lower the table, raise the backrest to the upright position, then depress and hold the Table Down pedal until the desired height is achieved, then release the pedal.
3. Press the blue button to engage the Return to Chair feature (Figure 36).



WARNING: Pinch Hazard

Keep hands safely away from area between the upholstered table top and the table cabinet when adjusting positions.

OPERATION (CONTINUED)

Return to Chair Button Models 5800, 5801, 5800PLUS & 5801PLUS

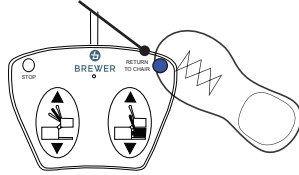

Figure 36. Lowering with Return to Chair

NOTICE: Actuator Travel Limit Protection

Each control function will automatically stop moving when either the UP or DOWN travel limit is reached. If the foot pedal is pressed with travel at its limit, the actuator will not operate. Sensors prevent the actuator motor from operating when travel limit has been reached, preventing wear of the actuator.

NOTICE: Fuse Protected

The control system is protected by a fuse to prevent excessive current draw which could damage the system. If operation does not resume after a cooling period of one hour, contact Brewer 1-800-558-8777.

Seat Back

The back can be adjusted to any angle between horizontal and 80°.

NOTICE: To Lower Backrest Fully

Table must be raised to a height of 28" or 27" for "PLUS-17" before the backrest can be lowered to the horizontal position (Figure 37).

Pneumatic Manual Backrest (Models 5700, 5701, 5700PLUS & 5701PLUS)

- To lower the seat back, push down on the seat back while pulling the release handle upward.



CAUTION

Backrest Lowering Hazard

Depressing the manual backrest release handle while a patient is seated on the table can cause the backrest to lower rapidly. Lower the backrest in increments by depressing and releasing the handle. Allowing the backrest to lower in a single motion could cause injury to the patient.

- To raise the seat back, place hand on the backrest to prevent it from rising rapidly, and then pull the release handle upward. The seat back will lock in the desired position when the handle is released.

NOTE: *The pneumatic backrest cylinder does not exert enough force to raise the backrest with a patient lying on the table.*

OPERATION (CONTINUED)

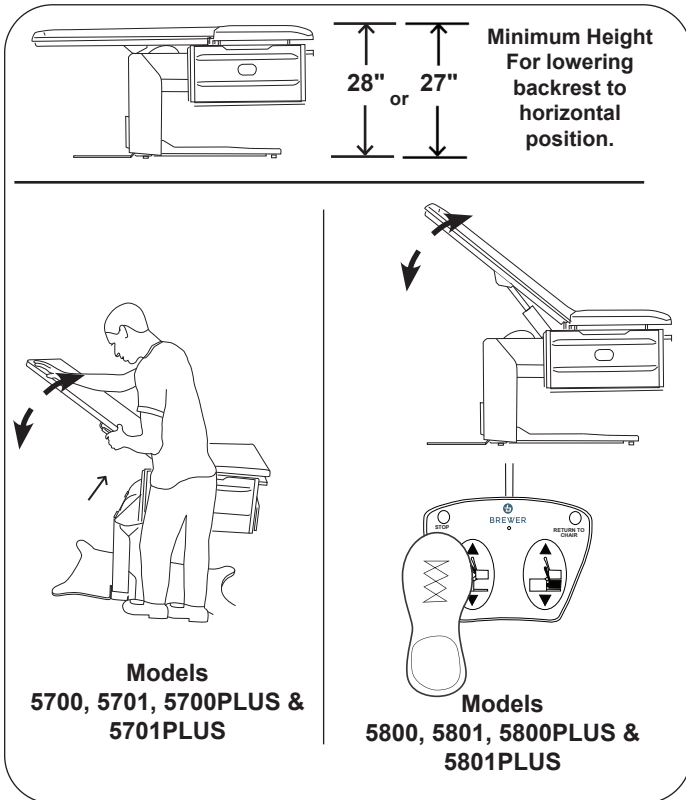

Figure 37. Adjusting Seat Back - actual model may appear different

Powered Backrest (Models 5800, 5801, 5800PLUS & 5801PLUS)

1. To lower the seat back, depress and hold the Back Down pedal until the desired angle is achieved, then release the pedal.
2. To raise the seat back, depress and hold the Back Up pedal until the desired angle is achieved, then release the pedal.

NOTICE: Power Back Actuator-Push Only

On power back models, the back is positioned by a "push only" actuator that raises the back. When lowered, the actuator retracts and gravity causes the back to lower.

NOTICE: Avoid Continuous Operation

The table's control system includes a thermal overload safety switch to protect from overheating. If the table is operated continuously causing the control to exceed its allowable operating temperature, the thermal overload safety switch will shut off. If normal operation ceases, do not attempt to operate the table. Allow the table to cool for 10-15 minutes before attempting to use again. The thermal overload switch will automatically reset when it has reached a safe operating temperature.

Manual Pelvic Tilt (Models 5701, 5801, 5701PLUS and 5801PLUS)

The manual pelvic tilt feature sets the seat angle at 0° (horizontal) or 6° (up) position.

Pull up on the front of the seat and the pelvic tilt automatically travels to the locked tilt position (Figure 38).

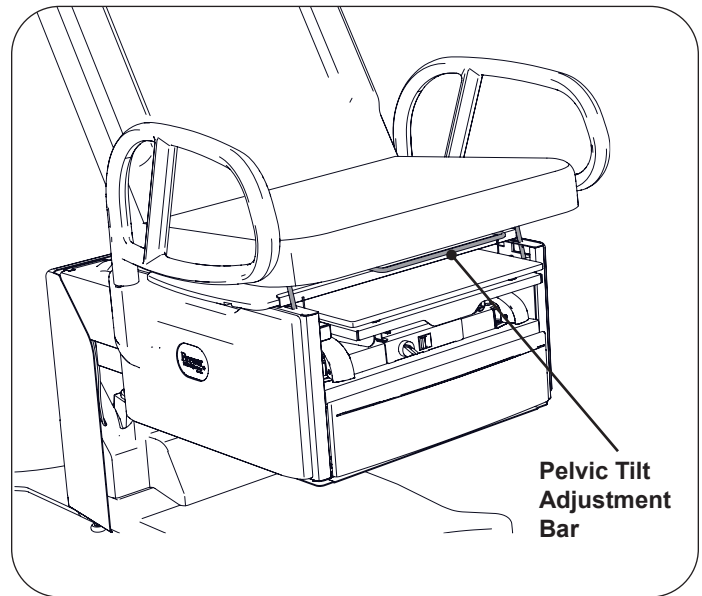

Figure 38. Pelvic Tilt Adjustment

NOTICE: Engaging the Pelvic Tilt Mechanism

Pulling up with excessive force can damage the pelvic tilt mechanism. Lift only with enough force to engage mechanism.

To lower seat, lift the adjustment lever and lower the seat to the horizontal position.

NOTICE: Lowering the Pelvic Tilt Mechanism

Patient must be removed from table prior to lowering the pelvic tilt mechanism.

OPERATION (CONTINUED)

Front Drawer Warmer (Models 5701, 5801, 5701PLUS and 5801PLUS)

Models 5701, 5801, 5701PLUS and 5801PLUS are equipped with a drawer warmer that is turned on by a switch located above the drawer (Figure 39).

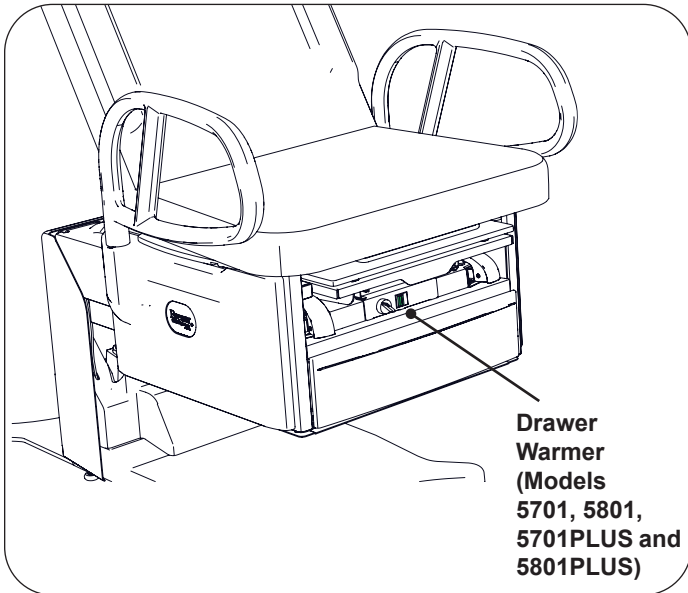

Figure 39. Front Drawer Warmer Switch

NOTICE: Proper Loading of the Front Drawer

Do not stack instruments in the front drawer. Place instruments in one layer in the bottom of the drawer.

Outlet (Models 5701, 5801, 5701PLUS and 5801PLUS)

Models 5701, 5801, 5701PLUS and 5801PLUS are equipped with an Outlet (Figure 40). The maximum total load that can be plugged into the outlet is 2 amps.

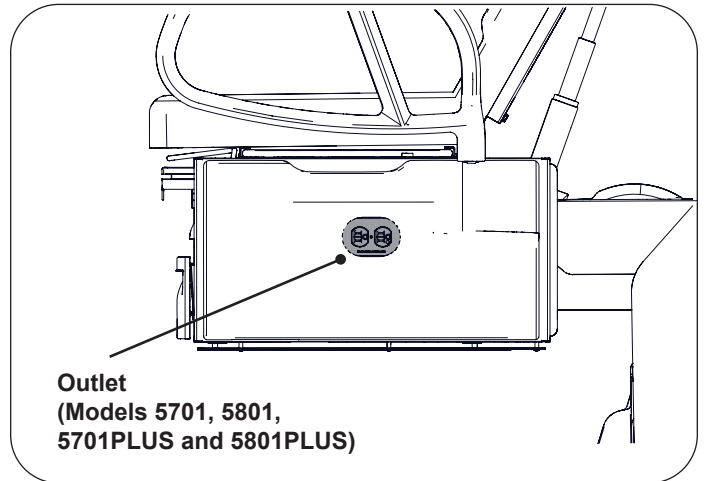

Figure 40. Table Outlet

NOTICE: Maximum Outlet Rating

Plugging a device into the outlet on the side of the table with rating higher than 2 amps may cause the fuse at the back of the table to blow.

OPERATION (CONTINUED)

EasyGlide Mobility Option (Available option for all PLUS Models)

To engage EasyGlide mobility option (deploy wheels on table to enable movement around the exam room):

1. Ensure there is power to the table (power cord is plugged in).
2. Locate the EasyGlide mobility activation switch on the front of the table below the upholstered seat.
3. Turn the switch clockwise to the upper position shown in Figure 41, indicated by the table movement decal.



Figure 41. EasyGlide Mobility Option Switch

4. Wait for the central wheels to lower (up to six seconds). Once the wheels begin deploying, the rotary switch will illuminate.

Once EasyGlide is deployed, the table can be rotated and moved around the exam room to accommodate cleaning and positioning of other medical equipment needed for exams. Users can adjust the position of the seat so the assist handles are at a comfortable height when moving the exam table. Grasp the front of the assist handles when moving the table (Figure 42).

NOTE: If assist handles are not installed on the table, push and/or pull from the front of the upholstered seat. Do not lift the underside of the seat.

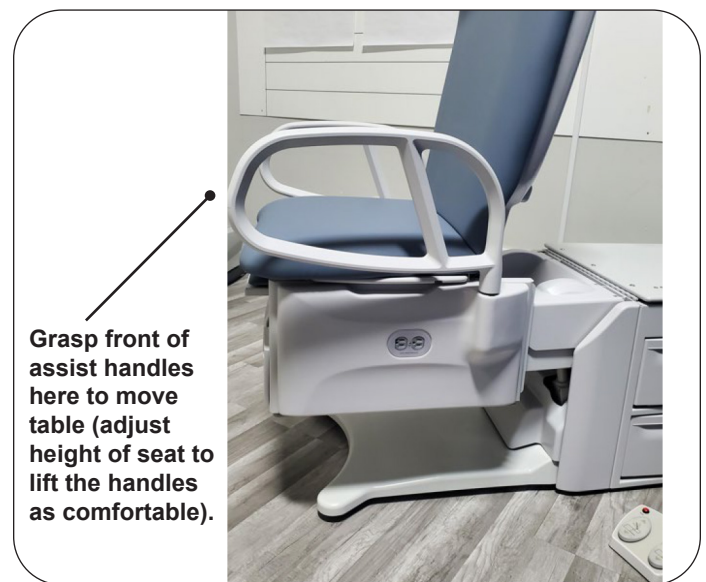



Figure 42. Position Assist Handles to Move Table

To disengage EasyGlide mobility option (retract wheels on table and disable movement):

1. Ensure there is power to the table (power cord is plugged in).
2. Locate the EasyGlide mobility activation switch on the front of the table below the upholstered seat.
3. Turn the switch counter-clockwise to the lower position (indicated by the no table movement decal). When the wheels are fully retracted, the switch will no longer be lit.

OPERATION (CONTINUED)

EasyGlide Mobility Option Warnings/ Cautions/Notices

	<p style="text-align: center;">WARNING: Fall Hazard</p> <p>The mobility feature is not intended to be used with a patient on the table.</p>
-----------------------------------------------------------------------------------	----------------------------------------------------------------------------------------------------------------------------------------------------

	<p style="text-align: center;">WARNING: Pinch Hazard</p> <p>Before and during downward movement, keep personnel and equipment clear of table to avoid personal injury or damage to the equipment. The mobility option could remain active even if the switch light is not illuminated.</p>
-----------------------------------------------------------------------------------	---------------------------------------------------------------------------------------------------------------------------------------------------------------------------------------------------------------------------------------------------------------------------------------------------

	<p style="text-align: center;">CAUTION: Pinch Hazard</p> <p>The exam table should only be moved with storage drawers, work surface, and leg extension pushed in/not deployed.</p>
-----------------------------------------------------------------------------------	------------------------------------------------------------------------------------------------------------------------------------------------------------------------------------------

	<p style="text-align: center;">CAUTION: Pinch Hazard</p> <p>If power is removed at any time, the mobility feature will remain in its current state.</p>
-----------------------------------------------------------------------------------	----------------------------------------------------------------------------------------------------------------------------------------------------------------

<p style="text-align: center;">NOTICE</p> <p>EasyGlide mobility option allows the exam table to be moved for cleaning and disinfection, or to accommodate other exam room equipment. For instructions on transferring the table outside of the exam room, please refer to the Installation instructions in this document.</p>	
--------------------------------------------------------------------------------------------------------------------------------------------------------------------------------------------------------------------------------------------------------------------------------------------------------------------------------------	--

<p style="text-align: center;">NOTICE</p> <p>For optimal operation, do not run Return to Chair feature while engaging or disengaging the EasyGlide mobility option.</p>	
--------------------------------------------------------------------------------------------------------------------------------------------------------------------------------	--

	<p style="text-align: center;">CAUTION</p> <p>The EasyGlide mobility option is meant to be used on level or mostly level flooring surfaces. Use on unlevel surfaces may cause unintended movement.</p>
-------------------------------------------------------------------------------------	---------------------------------------------------------------------------------------------------------------------------------------------------------------------------------------------------------------

	<p style="text-align: center;">CAUTION</p> <p>Do not turn the EasyGlide mobility switch when the table is not plugged in to avoid the switch indicating the wrong state.</p>
-------------------------------------------------------------------------------------	-------------------------------------------------------------------------------------------------------------------------------------------------------------------------------------

	<p style="text-align: center;">CAUTION: Automatic Startup</p> <p>When plugged in the EasyGlide mobility option will go to the indicated state if it is not already there.</p>
-------------------------------------------------------------------------------------	--------------------------------------------------------------------------------------------------------------------------------------------------------------------------------------

<p style="text-align: center;">NOTICE</p> <p>The EasyGlide mobility option works best with the backrest up.</p>	
------------------------------------------------------------------------------------------------------------------------	--

MAINTENANCE



WARNING: Shock Hazard

Disconnect power by removing plug from wall receptacle before servicing table. Failure to do so may result in electrical shock.



CAUTION

Only use the receptacle to supply power to equipment intended to form part of the medical electrical system.

Preventative Maintenance

NOTICE: Loose Fasteners and Damaged Components

Failure to perform periodic inspections of the table could result in equipment damage.

- Inspect table every 6 months.
- Periodically inspect the electrical cord to ensure it is free of cuts or damage if equipped.
- Inspect the mechanical functions to ensure satisfactory operation.
- Check fasteners to make sure they are present and tightened securely.
- Lubricate moving parts (such as back hinge) with a food grade silicone lubricant. Cover surrounding area to protect from overspray. Wipe away excess lubricant. Do not lubricate beam or locking mechanism in stirrup area.

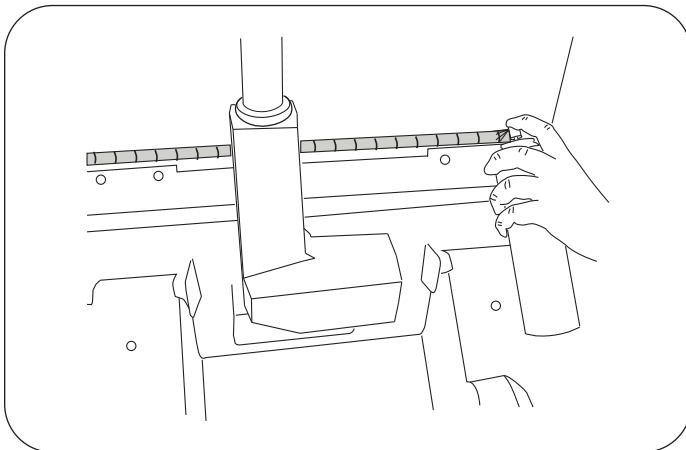

Figure 43. Lubricating the Backrest Hinge

NOTICE: Table Malfunction

If table malfunctions, immediately unplug the power cord from the receptacle and assist the patient from the table. Service the table prior to use.

Table Care

NOTICE: Wipe Spills Immediately!

The upholstery material is resistant to most medical type stains, but may be damaged by solvents and dyes. Remove any spilled fluids from the upholstery immediately.

Improper cleaning products used on Brewer tables can decrease the life of the table. Always follow Brewer's Cleaning guidelines. You can view the latest guidelines at brewercompany.com/resources.

Proper Disposal

Follow local and state guidelines for proper disposal of product.

SERVICE

**WARNING: Shock Hazard**

Disconnect power by removing plug from wall receptacle before servicing table.

Fuse Replacement

Tables with Drawer Warmer and Outlet (Models 5701, 5801, 5701PLUS and 5801PLUS)

1. Unplug table from wall receptacle.
2. Fuse is located at the back of the table near the power cord.
3. Push the fuse holder cap in with a flat screwdriver and rotate 1/4 turn counterclockwise to remove cap and fuse (Figure 44).

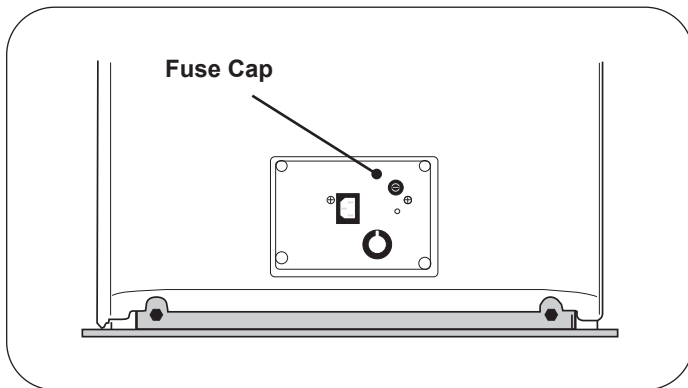

Figure 44. Fuse Cap

4. Replace fuse with Brewer 2102490, 3A 250V fuse.
5. Push new fuse into cap.
6. Push cap with fuse into holder and rotate 1/4 turn clockwise to install.
7. Plug table into wall receptacle.
8. Check drawer warmer and outlet for proper function, if equipped.

ACCESSORIES

Refer to the Brewer website www.brewercompany.com for a list of current accessories.

POWER CORD OPTIONS

NOTICE

This table must be used with a Brewer provided power cord.
Failure to do so will void the warranty of electrical components.

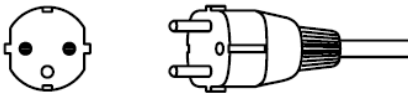
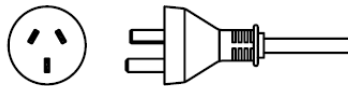
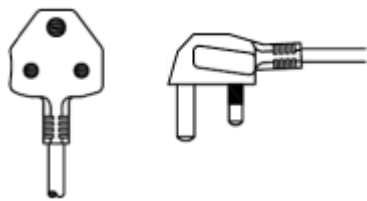
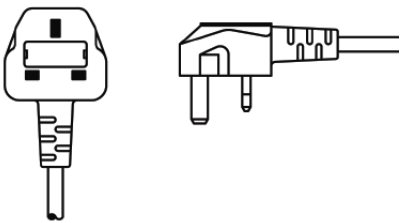
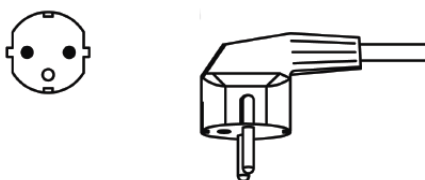
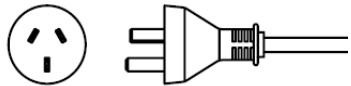
Power Cord Plug Type	Brewer Part No.	Countries Typically Used In
 EU1-16P, CEE 7/7	101941	Thailand Laos Vietnam Philippines Indonesia Cambodia
 CH1-10P	101942	China Mongolia
 UK2-15P (BS 546 A)	101493	Macau Bangladesh
 UK1-13P, -BS 1363A	101944	Myanmar Hong Kong Singapore Malaysia
 KSC-8305 SK1-16P	101945	South Korea
 AU1-10P	2102545	Australia

WARRANTY

For Brewer Warranty Information:

Registering your Brewer product is easy. Simply go to brewercompany.com/contact/warranty-registration, fill out the information fields and click send. By registering your product today, you are better safeguarding your investment in the future.