

BrewerElement

TREATMENT TABLE

Model 2210

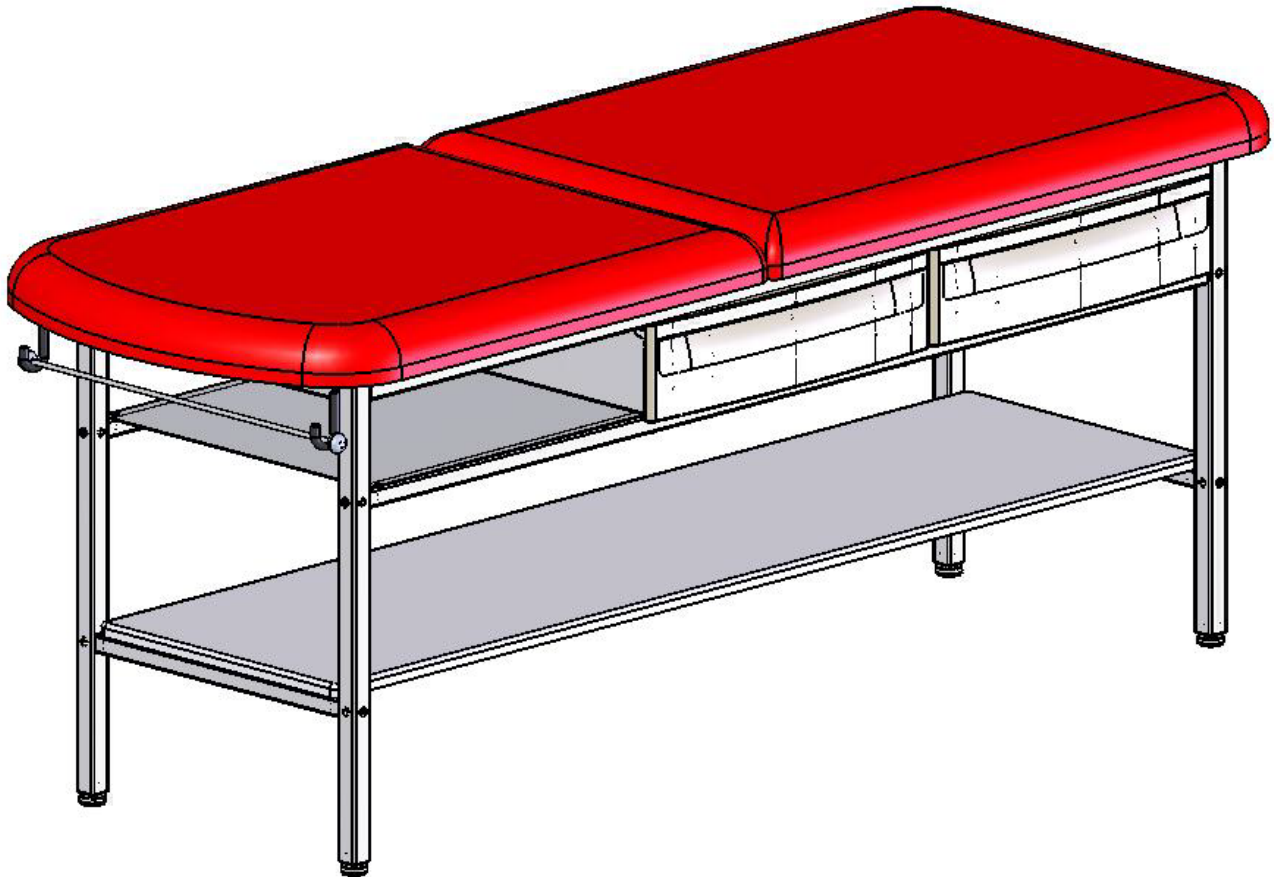

Overview	2	Drawer Removal	11
Tools Needed	2	Maintenance	12
Hardware.....	2	Accessories	12
Assembly.....	3-10	Limited Warranty	12
Installation.....	11		

Brewer
more possibilities

The Brewer Company
13901 Main Street
Menomonee Falls, WI 53051
P 1.888.Brewer.1
F 262.251.1786
www.brewercompany.com

OVERVIEW

Perform the following sequence in order when setting up the table:

- Unpacking
- Assembly
- Leveling the Table
- Installing the Paper Roll

NOTE: Save all packaging in case re-shipment is required.

NOTE: Inspect all boxes and contents for damage. Report any damage to the carrier immediately.

MODEL 2210

For the above model you will receive three separate cartons: a frame & shelf carton, an upholstery carton, and a drawer carton. Inspect all three carefully for shipping incurred damage.

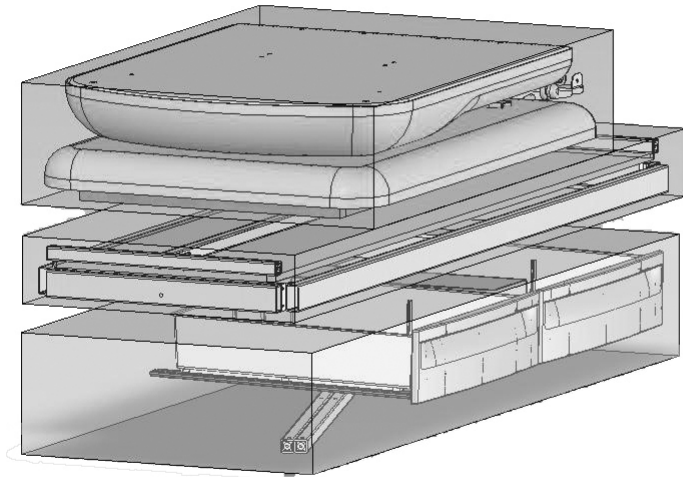

⚠ WARNING
Two or more people should assist in moving the table. Use proper lifting techniques when lifting. Failure to do so could result in serious injury!

⚠ CAUTION
To avoid damaging the table's upholstery or painted surfaces, DO NOT use a knife or any other sharp object to open the packaging.

MODEL 2210 TOOLS NEEDED

9/16" Open End Wrench

11/32" Socket or Wrench

Phillips Screw Driver

MODEL 2210 HARDWARE

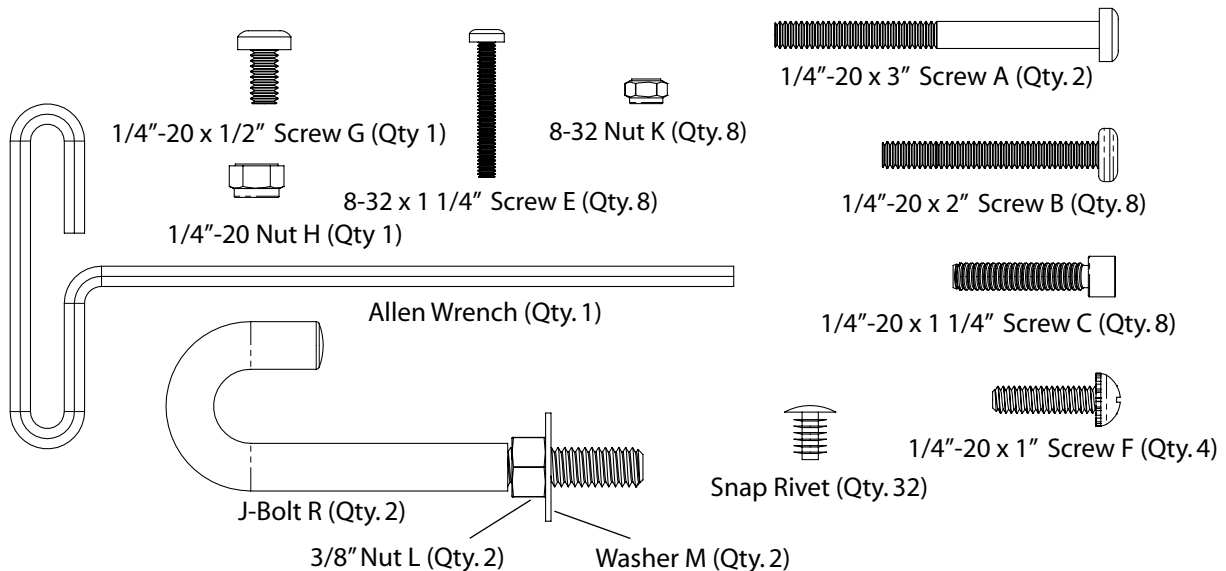

MODEL 2210 STEP 1

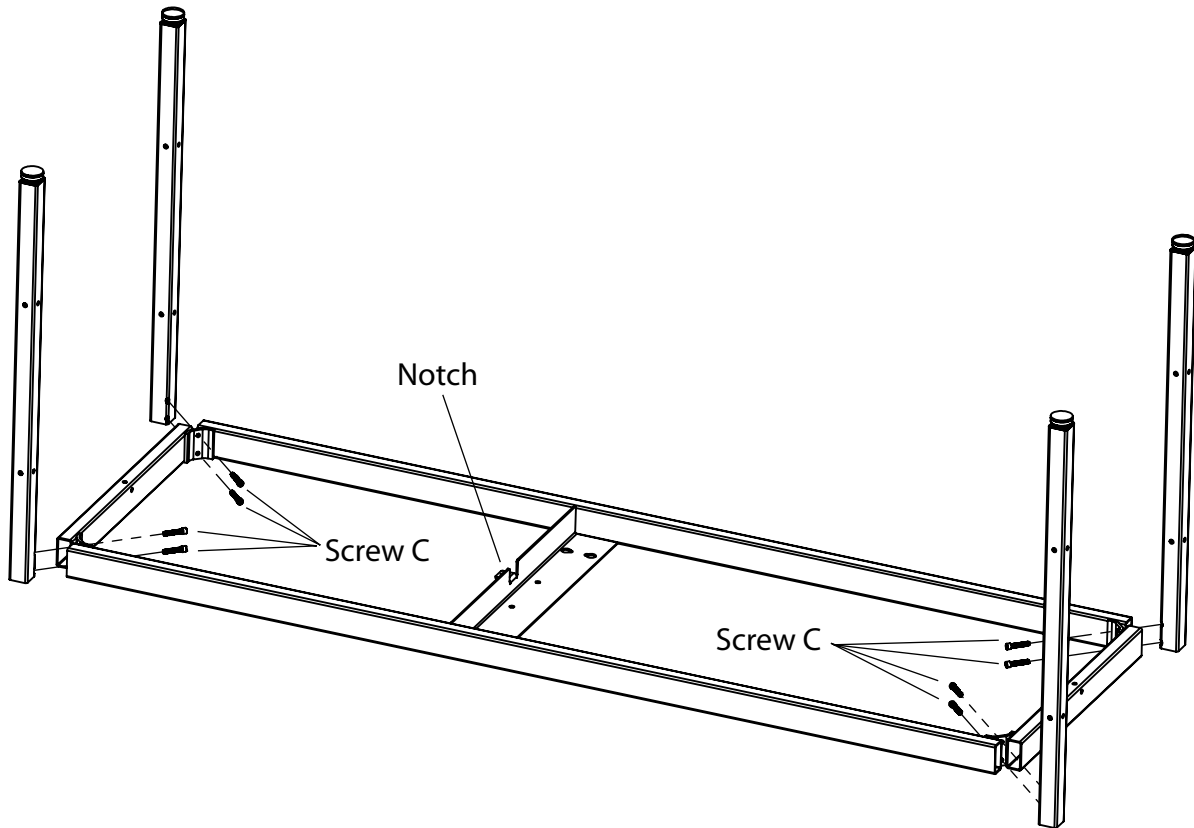

STEP A: Start with table frame inverted: note the position of the Notch in the drawing above is facing upwards.

STEP B: Position Legs in corners (see drawing above). Insert Screws C (1/4"-20 x 1 1/4") and snug up by hand only at this time.

MODEL 2210 STEP 2

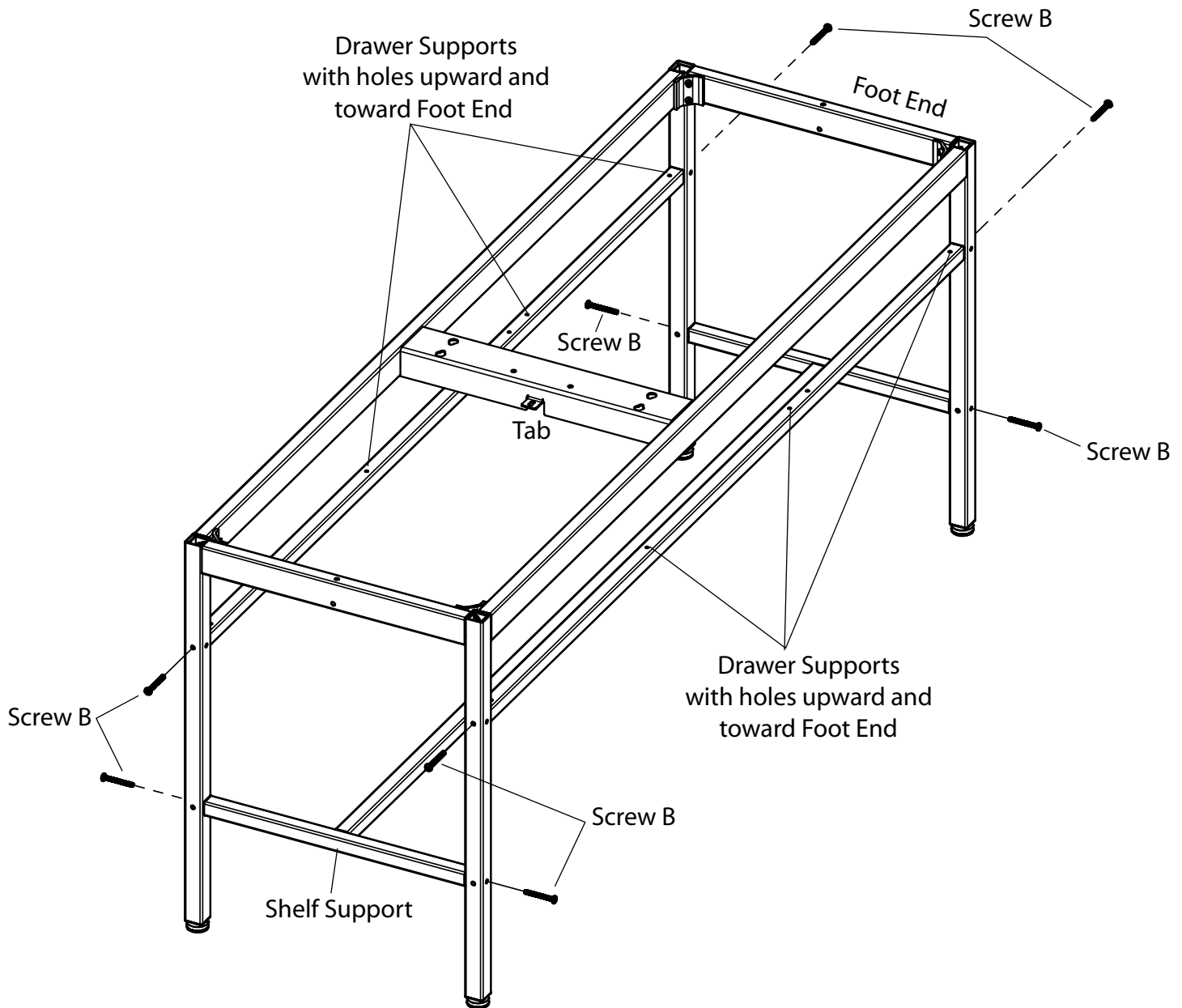

STEP A: With table in the upright position install Shelf Support using 4 Screws B (1/4"-20 x 2"). Do not tighten at this time.

STEP B: Locate Drawer Supports according to above drawing so that the holes through the tube are facing up, and the holes nearest the ends of the tubes are at the Foot End of the table. Install using 4 Screws B (1/4"-20 x 2"). Do not tighten at this time.

MODEL 2210 STEP 3

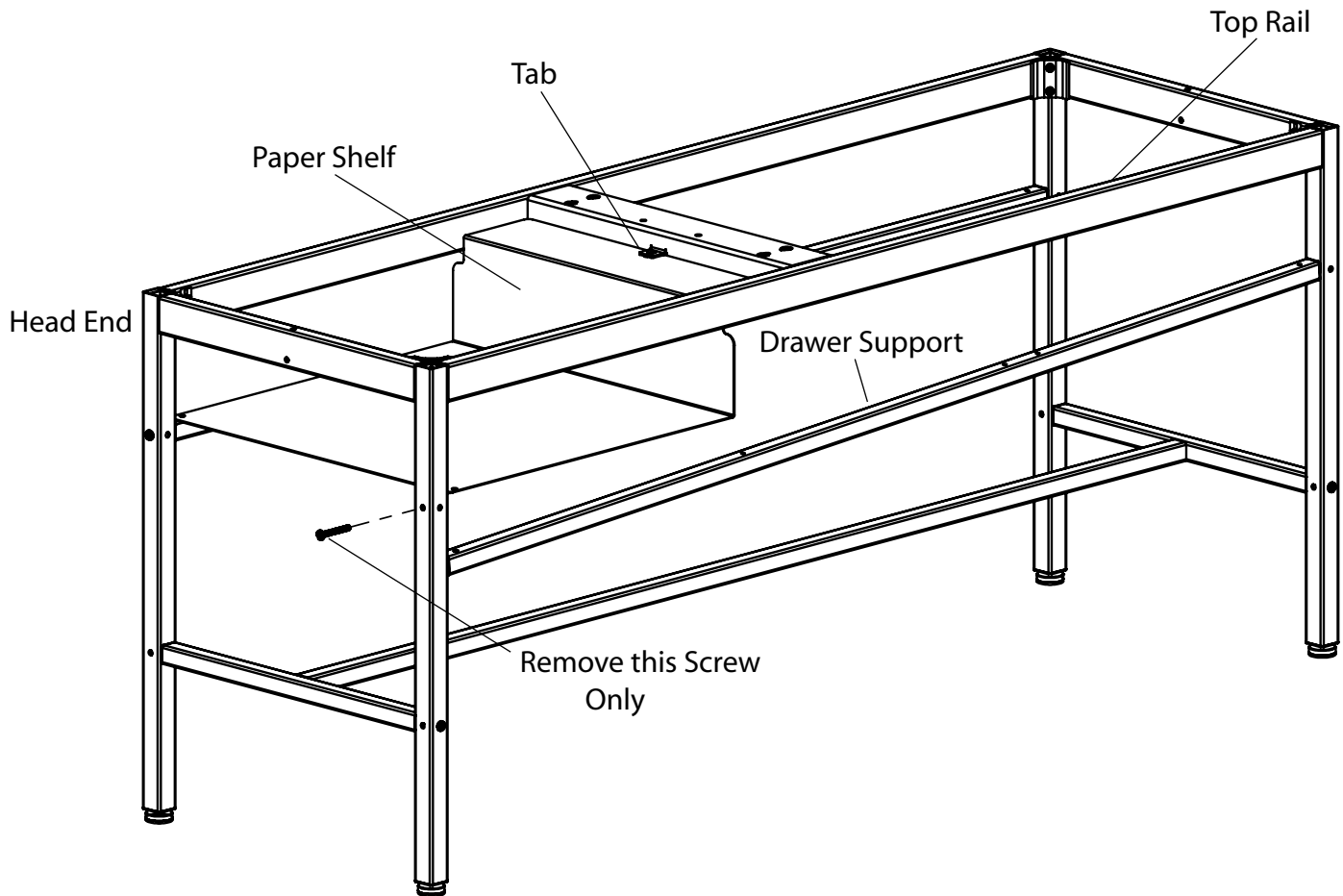

STEP A: Remove one Drawer Support screw from the Head End of the table as shown.

STEP B: Insert Paper Shelf between the Top Rail and the loose Drawer Support. Make sure the Paper Shelf is mounted below the Tab as shown.

STEP C: Reinstall the Drawer Support and its corresponding screw. Do not tighten at this time.

MODEL 2210 STEP 4

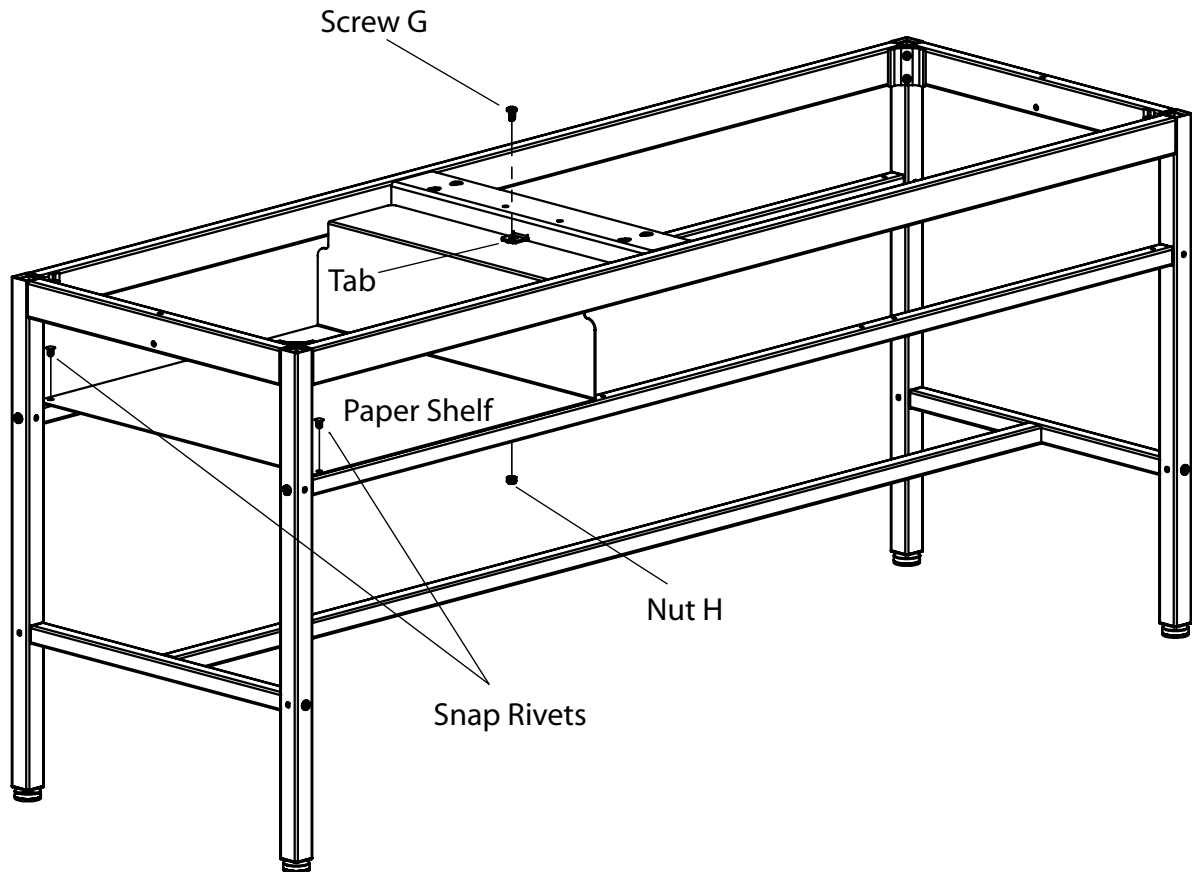

STEP A: Install Screw G (1/4"-20 x 1/2") through Tab and Paper Shelf as shown. Tighten Nut H (1/4"-20) onto Screw G. Install 3 Snap Rivets into holes on Paper Shelf and the top of the frame rail.

MODEL 2210 STEP 5

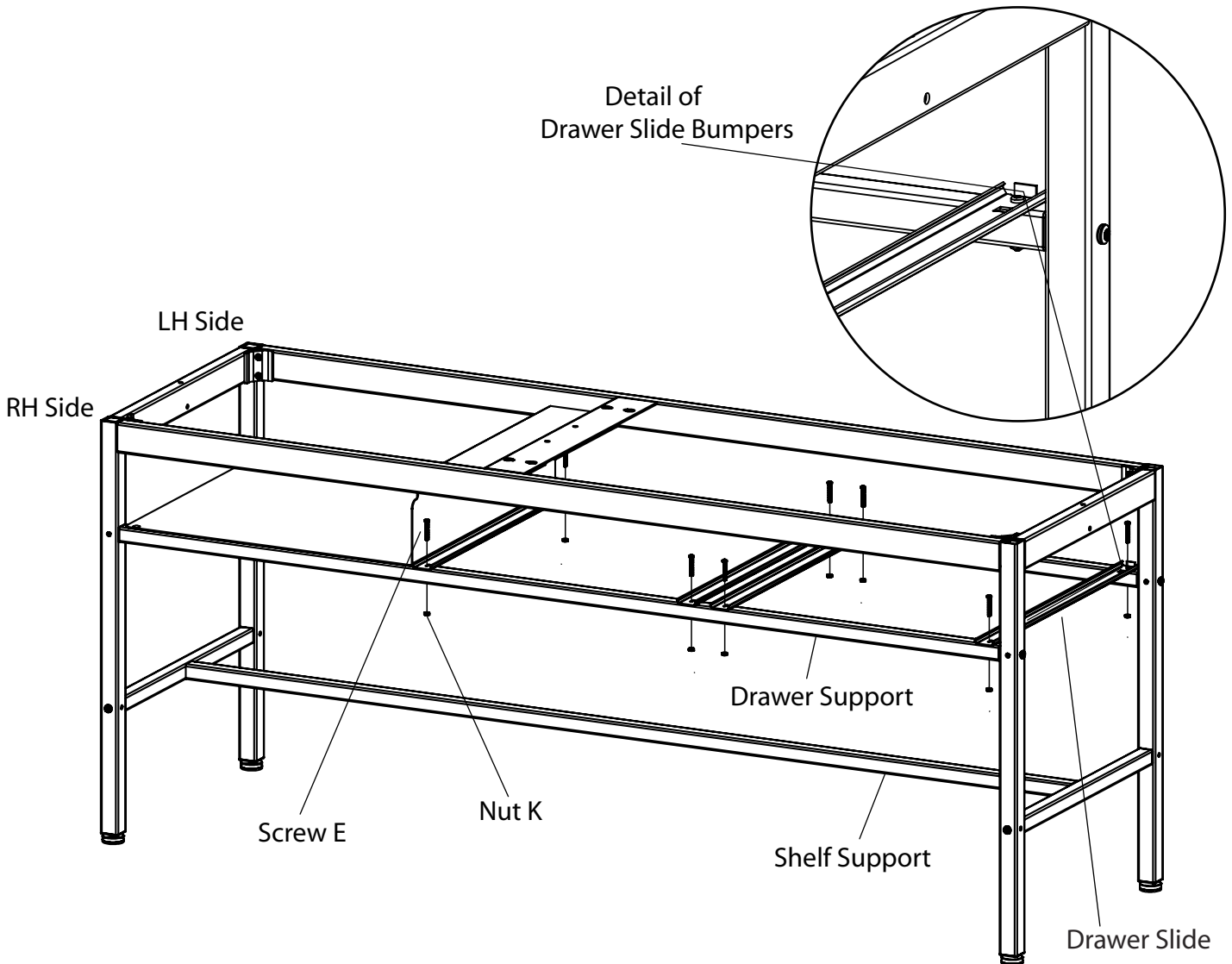

STEP A: The drawers can be installed so they open from the right hand side (RH Side) or the left hand side (LH Side) of the table. The view above and the instructions below are for right hand installation.

STEP B: Position the (4) Drawer Slides on top of the Drawer Support rails. The rubber bumpers should be on the LH Side of the table, facing upward.

STEP C: Tighten Screws E (8-32 x 1 1/4") into Nuts K (8-32) at 8 locations.

STEP D: **Tighten all screws at this time.**

- Legs to Frame (8 screws using Allen Wrench provided)
- Drawer Supports to Legs (4 screws)
- Shelf Support to Legs (4 screws)

MODEL 2210 STEP 6

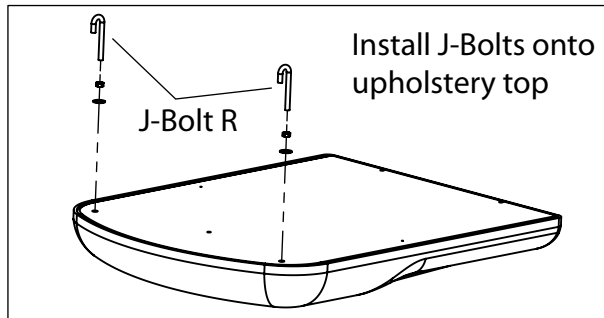
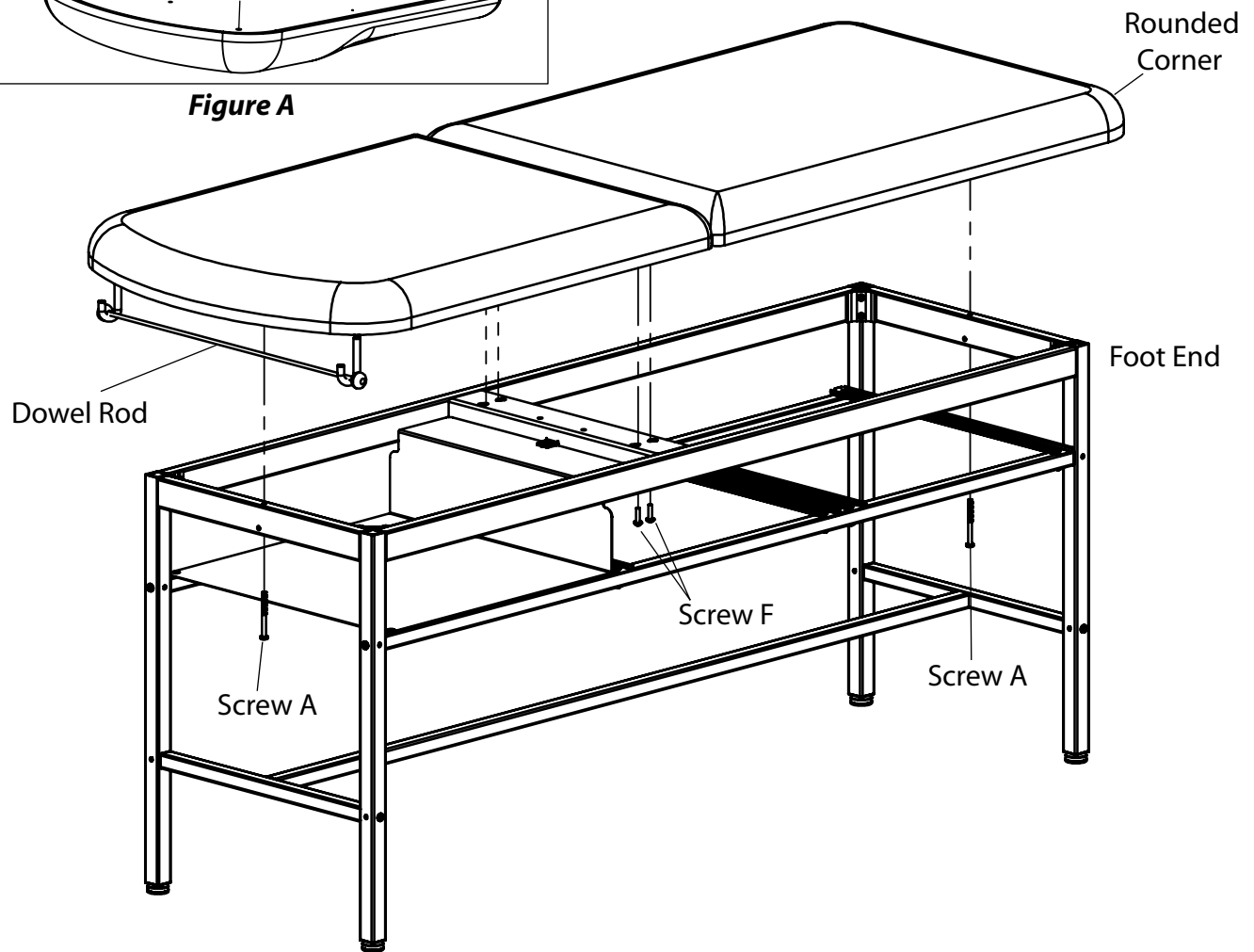

Figure A

STEP A: Install J-Bolts as shown in Figure A. Thread Nut L (3/8") completely onto J-Bolt. Place Washer M onto J-Bolt and thread into Backrest as shown in Figure A. Position J-Bolt toward head of table as shown and tighten nut against backrest.



STEP B: Set upholstery top and bottom on frame, with Rounded Corners of the upholstery bottom placed at the Foot End of the table.

STEP C: Install 2 Screws A (1/4"-20 x 3") through frame and into upholstery.

STEP D: Install 4 Screws F (1/4"-20 x 1") through frame and into upholstery.

STEP E: Tighten Screws.

STEP F: Slide the Dowel Rod through the paper roll and hang the Dowel Rod on the J-Bolts. Ensure a secure fit before using the paper roll dispenser.

MODEL 2210 STEP 7

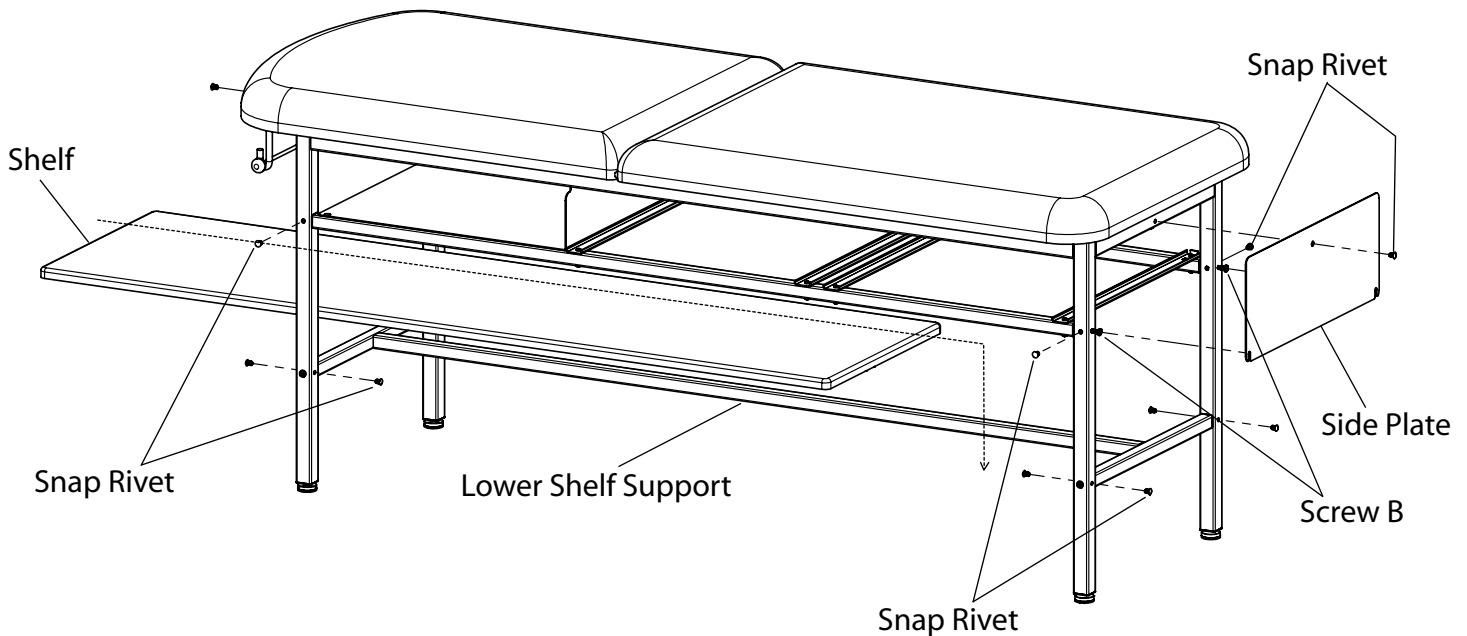

STEP A: Loosen Screws B at the foot of the table where indicated just enough to allow installation of the Side Plate.

STEP B: Mount Side Plate so that the slots of the plate straddle the Screws B that were just loosened.

STEP C: Press the top of the Side Plate up against the frame and align the top hole of the plate with the hole in the frame. Insert Snap Rivet into the aligned holes.

STEP D: Retighten Screws B.

STEP E: Insert the Shelf through either end of the table. Position the Shelf so that the locating blocks, on the bottom of the Shelf, are straddling the Lower Shelf Support.

STEP F: Install Snap Rivets into unused holes in legs and frame.

MODEL 2210 STEP 8

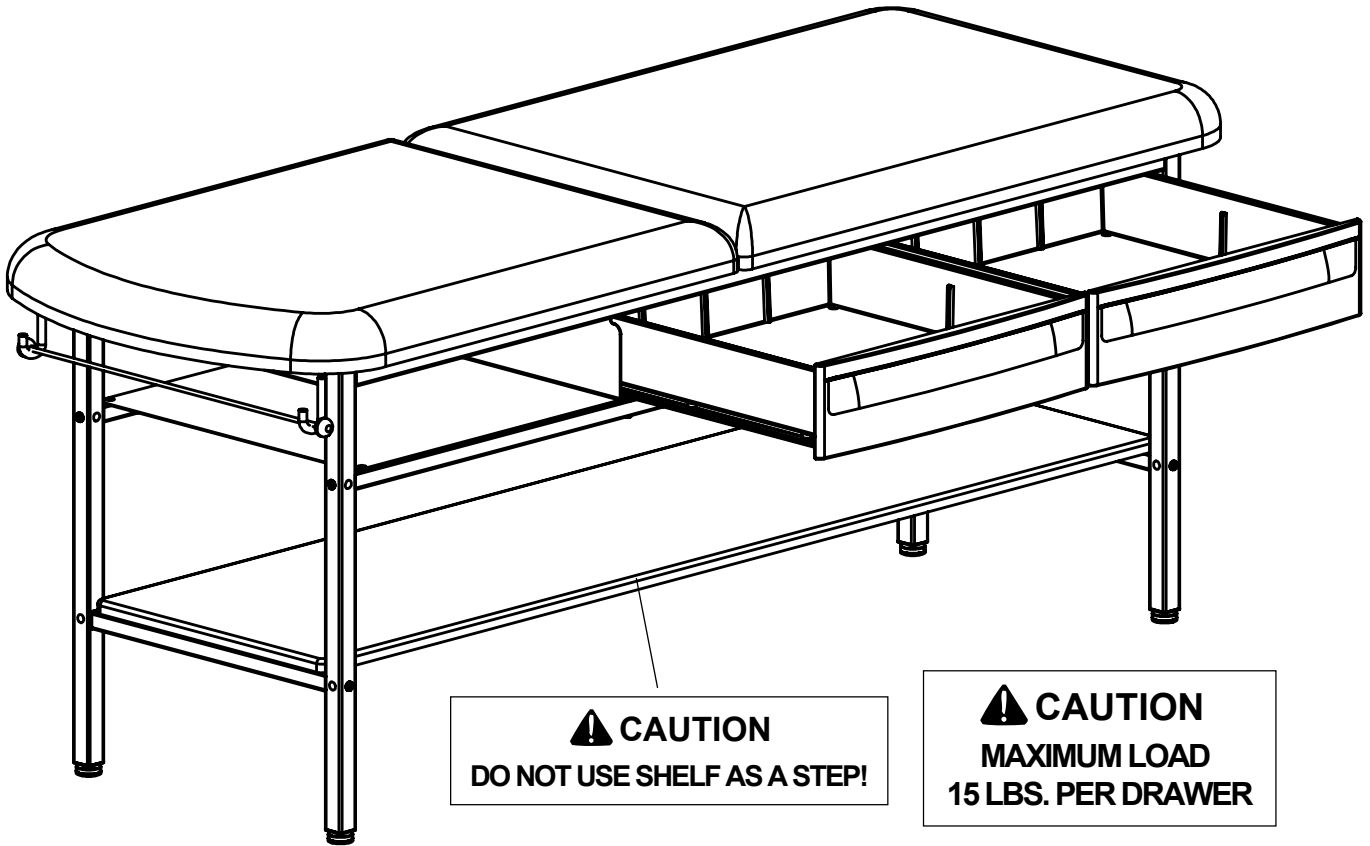

Drawer Slide Positioning

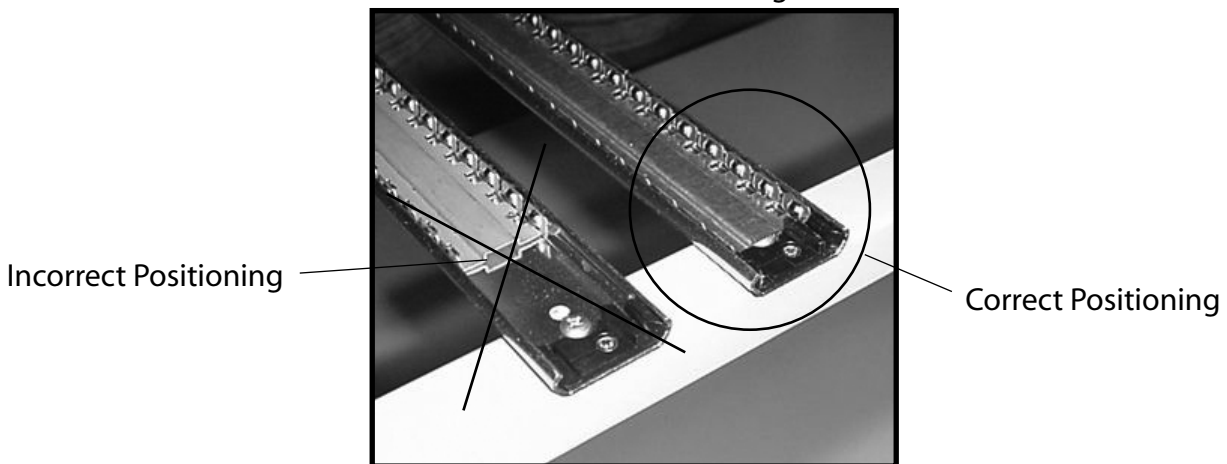

To install drawers, pull drawer slides forward and align the slots of the drawer-mounted slides to their mate on the frame. Push the drawers inward until they reach their fully-closed position.

INSTALLATION

Leveling the Table

A Leveling Screw Pad is located at each corner under the table's base. Adjust the four Leveling Screw Pads, by turning them up or down, to achieve a solid, level installation.

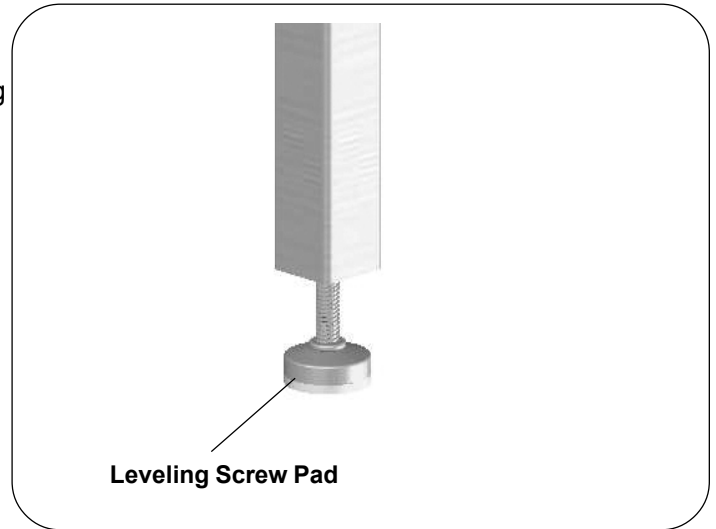

DRAWER REMOVAL

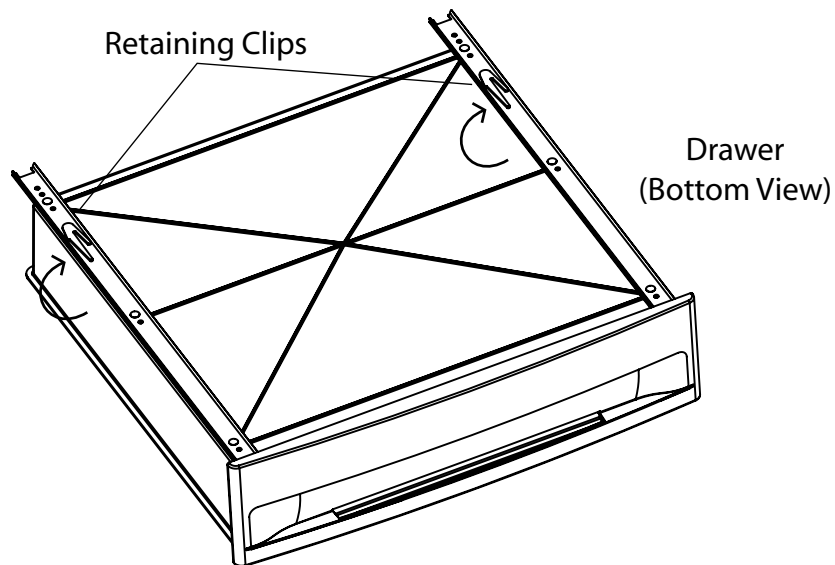

To remove Drawer from bottom slide support: Fully extend the Drawer, locate the Retaining Clips and push both clips in a clockwise direction as you pull the Drawer forward and out.

MAINTENANCE

Preventative Maintenance

- Inspect the mechanical functions to ensure satisfactory operation.
- Check fasteners to make sure they are present and secured tightly.

Cleaning

Upholstery

Regular care should be maintained by daily wiping with a damp cloth or sponge and periodic cleaning with a mild soap and water solution. Let air dry before placing anything on top of upholstery.

WARNING

The upholstery material that covers the top of the table is resistant to most medicinal-type stains, but may be damaged by solvents and dyes. Remove any fluids which are spilled on the upholstery immediately. All surfaces should be cleaned within your facilities guidelines concerning antimicrobials and bloodborne pathogens.

Painted Metal Surfaces

Wipe all painted metal surfaces with a clean cloth at least once a week.

Drawers

Wipe out drawers with a damp cloth or sponge on a regular basis, along with periodic cleaning with a mild soap and water solution. The drawers may be removed for cleaning. (See page 11.)

ACCESSORIES

Description	Reorder No.	Use/Restrictions
Replacement Upholstery	210115-XX	Intended Use - Replacement top with hardware for 2210 Treatment Tables in 18 standard colors.
Special Upholstery	210115-SP	Intended Use - Allows the purchase of specialty vinyls in different colors with the model 2210 Treatment Tables. (Additional charges may apply.)
Front Drawer Organizer	100407	Intended Use - Optional front drawer dividers for separation and organization.
Paper Straps	10196	Intended Use - Secures paper in two locations to table.

The Brewer Company

GENERAL TERMS AND CONDITIONS

Warranty: The Brewer Company warrants its products to be free from defects in parts and workmanship under normal use and service for a period of three (3) years from date of shipment. The Brewer Company warrants its power tables to be free from defects in parts and workmanship under normal use and service for a period of three (3) years from date of shipment. The Brewer Company warrants its exam tables to be free from defects in parts and workmanship under normal use and service for a period of three (3) years from date of shipment. The Brewer Company warrants its lighting products to be free from defects in parts and workmanship under normal use and service for a period of one (1) year from date of shipment. The Brewer Company will not be responsible for any Product failure due to abuse, misuse, modification or improper use or for any use which exceeds the published capacity of the Product. Products returned by prepaid freight for inspection and found defective will, at the option of The Brewer Company, be repaired or replaced at no charge, but no claim for outside labor or other charges will be allowed. Products must not be returned without proper written authorization from The Brewer Company. Requests for authorization must be in writing and accompanied by the original purchase order, The Brewer Company invoice number and a copy of the invoice for the Product. THIS WARRANTY IS EXCLUSIVE AND IN LIEU OF ALL OTHER WARRANTIES AND REMEDIES WHATSOEVER, INCLUDING BUT NOT LIMITED TO IMPLIED WARRANTIES OF MERCHANTABILITY AND/OR FITNESS FOR A PARTICULAR PURPOSE. NO AGENT, EMPLOYEE, OR REPRESENTATIVE OF THE BREWER COMPANY HAS ANY AUTHORITY TO MAKE ANY AFFIRMATION, REPRESENTATION, OR WARRANTY NOT SET FORTH IN THESE TERMS AND CONDITIONS CONCERNING ANY PRODUCTS OF THE BREWER COMPANY. THE BREWER COMPANY SHALL HAVE NO LIABILITY WHATSOEVER FOR DAMAGES CAUSED BY TRANSPORTATION, ACCIDENTS, FIRE, UNAUTHORIZED ALTERATION, OR NORMAL WEAR OR ABUSE, NOR SHALL THE BREWER COMPANY HAVE ANY LIABILITY WHATSOEVER FOR ANY INCIDENTAL OR CONSEQUENTIAL DAMAGES, including without limitation, lost profits or any such damages arising from (a) the design, manufacture, sale, delivery, installation, repair, operation or use of products of The Brewer Company or any part thereof, (b) any actual or alleged failure or defect in products of The Brewer company or any part thereof, or (c) any actual or alleged breach or non-performance by The Brewer Company of this limited warranty.

Freight Claims: Upon receipt, merchandise should be carefully examined to ascertain that proper amount has been received in good condition. Any claim for shortage or damage must be made with delivering carrier within five (5) days from receipt of goods. We do not assume any responsibility for loss or damage in transit, and compensation for such loss must be obtained from the carrier.