

BrewerElement

TREATMENT TABLE

Model 2010

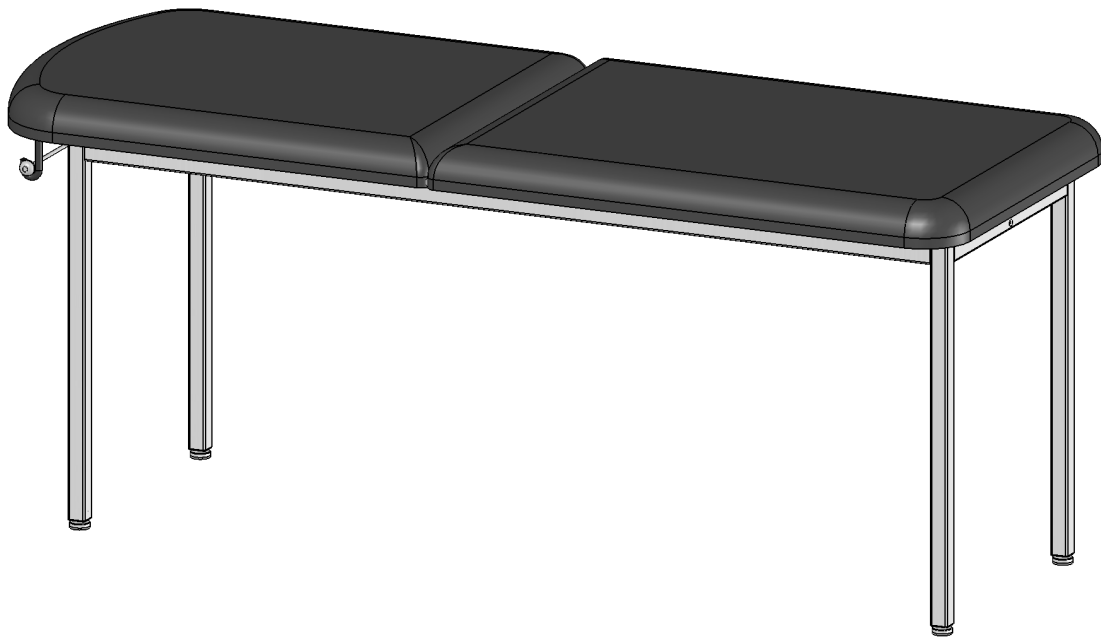

| | | | |
|-------------------|-----|------------------------|---|
| Overview | 2 | Installation..... | 5 |
| Tools Needed..... | 2 | Maintenance | 6 |
| Hardware..... | 2 | Accessories | 6 |
| Assembly..... | 3-4 | Limited Warranty | 6 |

Brewer
more possibilities

The Brewer Company
13901 Main Street
Menomonee Falls, WI 53051
P 1.888.Brewer.1
F 262 251 1786
www.brewercompany.com

OVERVIEW

Perform the following sequence in order when setting up the table:

- Unpacking
- Assembly
- Leveling the Table
- Installing the Paper Roll

NOTE: Save all packaging in case re-shipment is required.

NOTE: Inspect all boxes and contents for damage. Report any damage to the carrier immediately.

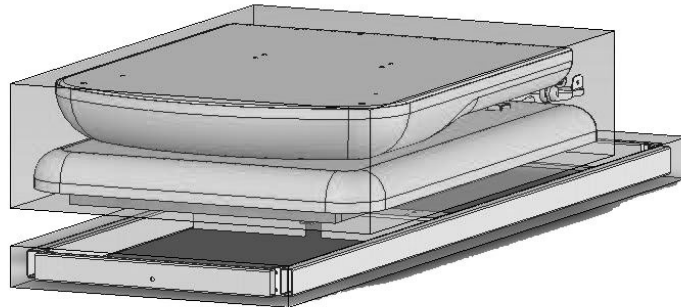

MODEL 2010

For the above models you will receive two separate cartons: a frame carton, and an upholstery carton. Inspect both carefully for shipping incurred damage.

⚠ WARNING
Two or more people should assist in moving the table. Use proper lifting techniques when lifting. Failure to do so could result in serious injury!

⚠ CAUTION
To avoid damaging the table's upholstery or painted surfaces, DO NOT use a knife or any other sharp object to open the packaging.

MODELS 2010 TOOLS NEEDED

9/16" Open End Wrench

Phillips Screw Driver

MODELS 2010 HARDWARE

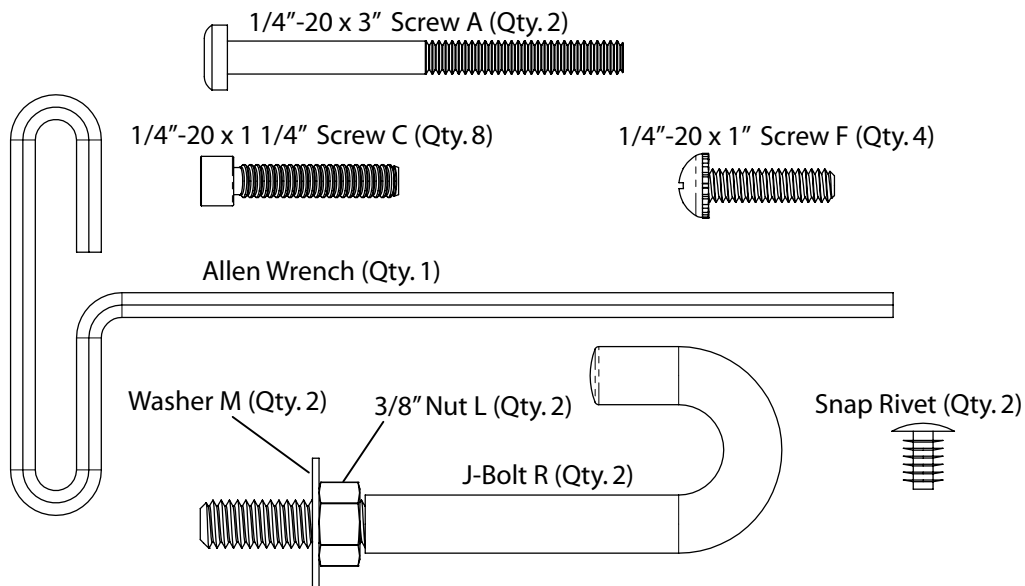

MODEL 2010 STEP 1

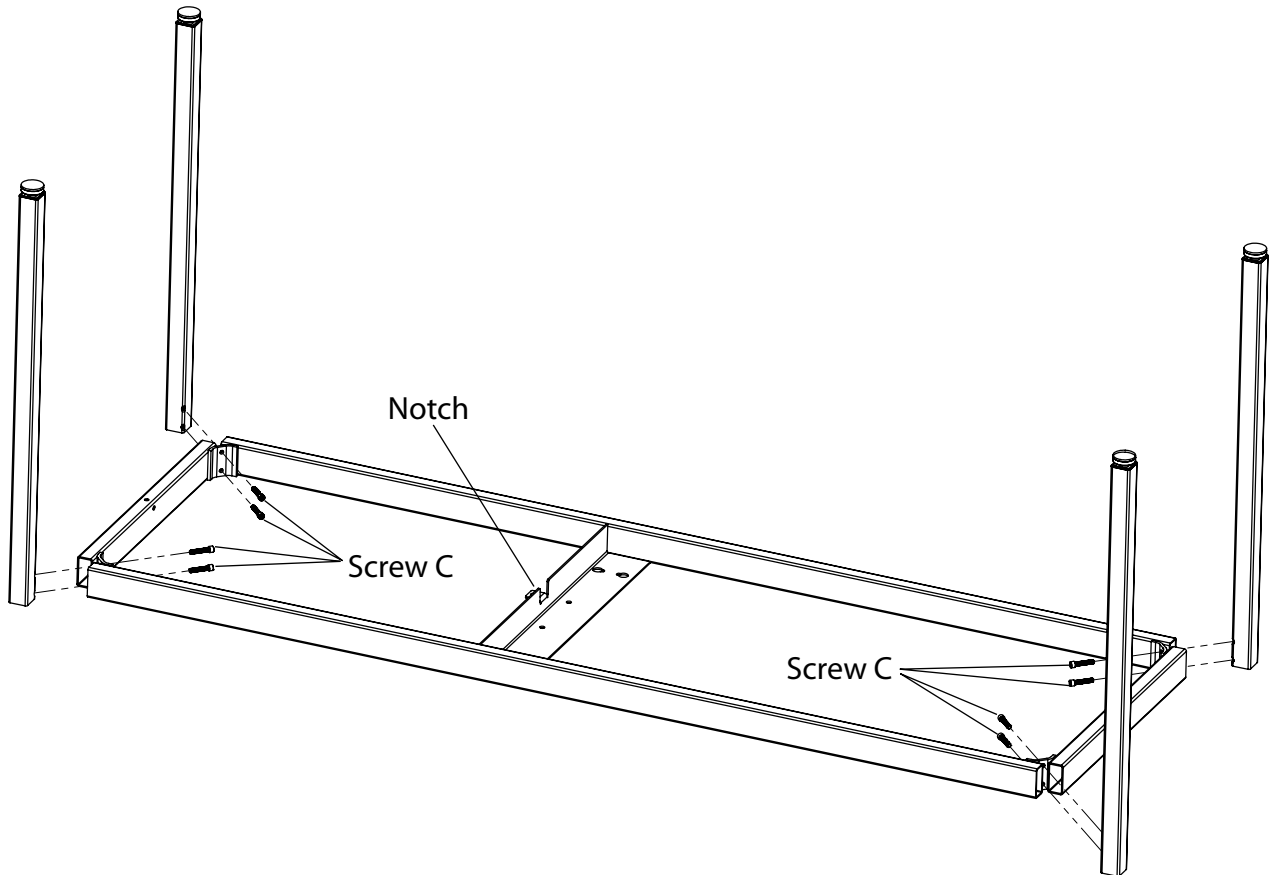

STEP A: Start with table frame inverted: note the position of the Notch in the drawing above is facing upwards.

STEP B: Position legs (see drawing above). Insert Screws C (1/4"-20 x 1 1/4") by hand. Tighten screws using Allen Wrench provided.

MODEL 2010 STEP 2

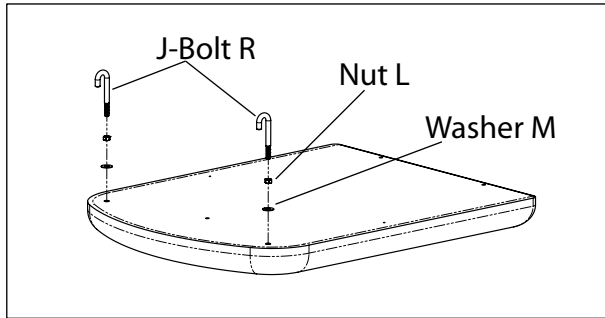
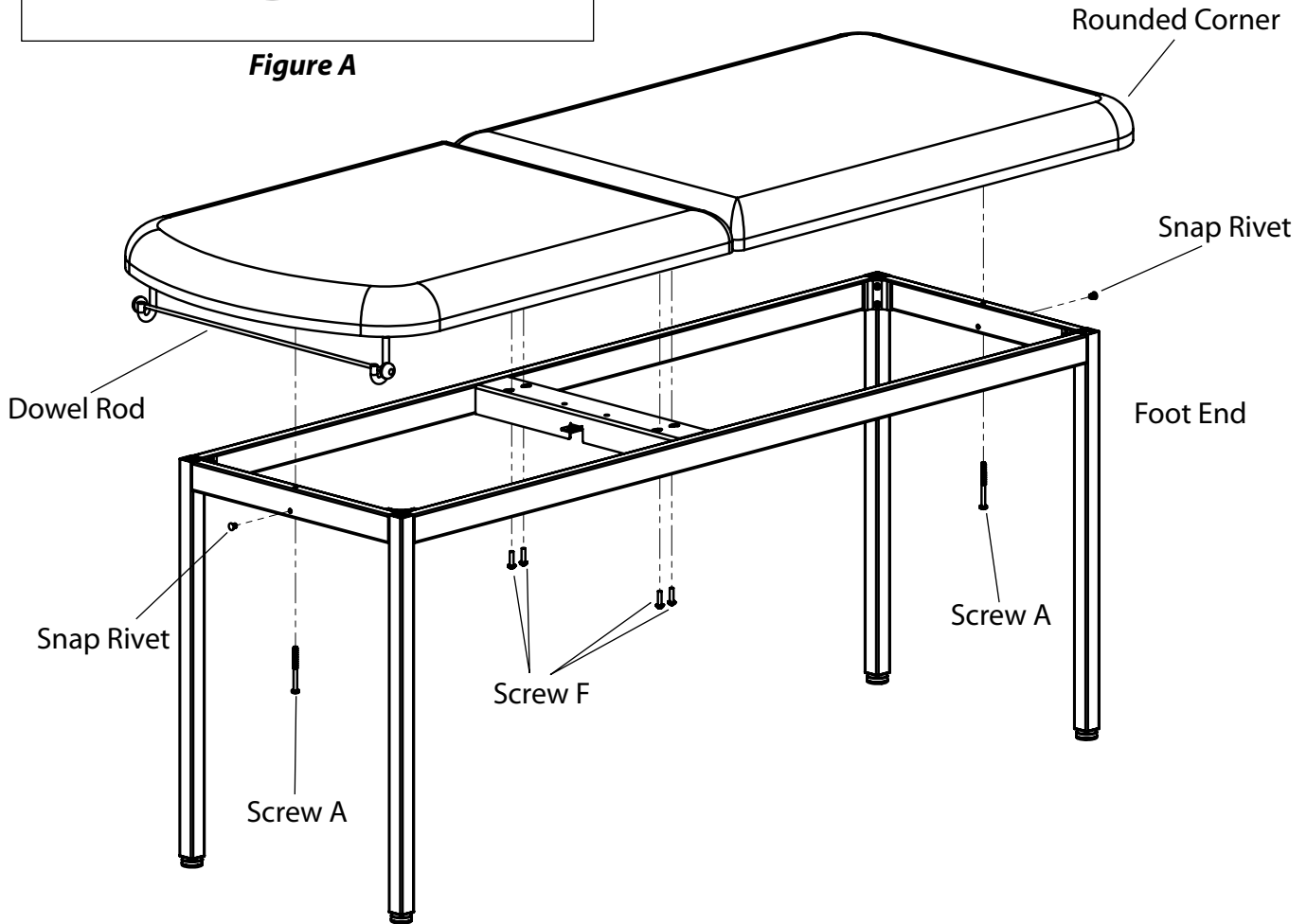

Figure A

STEP A: Install J-Bolts as shown in Figure A. Thread Nut L (3/8") completely onto J-Bolt. Place Washer M onto J-Bolt and thread into Backrest as shown in Figure A. Position J-Bolt toward head of table as shown and tighten nut against backrest.



STEP B: Set upholstery top and bottom on frame, with Rounded Corners of the upholstery bottom placed at the Foot End of the table.

STEP C: Install 2 Screws A (1/4"-20 x 3") through frame and into upholstery.

STEP D: Install 4 Screws F (1/4"-20 x 1") through frame and into upholstery.

STEP E: Tighten Screws and insert Snap Rivets as shown.

STEP F: Slide the Dowel Rod through the paper roll and hang the Dowel Rod on the J-Bolts. Ensure a secure fit before using the paper roll dispenser.

INSTALLATION

Leveling the Table

A Leveling Screw Pad is located at each corner under the table's base. Adjust the four Leveling Screw Pads, by turning them up or down, to achieve a solid, level installation.

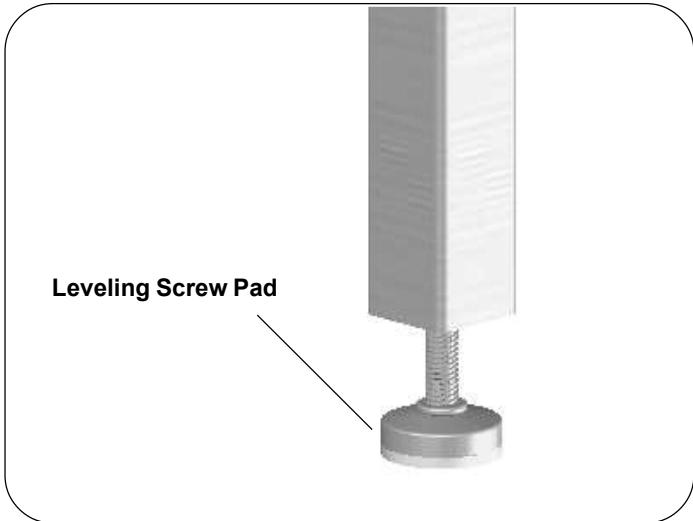

MAINTENANCE

Preventative Maintenance

- Inspect the mechanical functions to ensure satisfactory operation.
- Check fasteners to make sure they are present and secured tightly.

Cleaning

Upholstery

Regular care should be maintained by daily wiping with a damp cloth or sponge and periodic cleaning with a mild soap and water solution. Let air dry before placing anything on top of upholstery.

 **WARNING**

The upholstery material that covers the top of the table is resistant to most medicinal-type stains, but may be damaged by solvents and dyes. Remove any fluids which are spilled on the upholstery immediately. All surfaces should be cleaned within your facilities guidelines concerning antimicrobials and bloodborne pathogens.

Painted Metal Surfaces

Wipe all painted metal surfaces with a clean cloth at least once a week.

ACCESSORIES

| Description | Reorder No. | Use/Restrictions |
|------------------------|------------------------|--|
| Replacement Upholstery | 210115-XX 220115-XX | Intended Use - Replacement top with hardware for 2010 and 2020 Treatment Tables in 18 standard colors. |
| Special Upholstery | 210115-SP 220115-SP | Intended Use - Allows the purchase of specialty vinyls in different colors with the model 2010 Treatment Tables. (Additional charges may apply.) |
| Front Drawer Organizer | 100407 | Intended Use - Optional front drawer dividers for separation and organization. |
| Paper Straps | 10196 | Intended Use - Secures paper in two locations to table. |

LIMITED WARRANTY

The Brewer Company GENERAL TERMS AND CONDITIONS

Warranty: The Brewer Company warrants its products to be free from defects in parts and workmanship under normal use and service for a period of three (3) years from date of shipment. The Brewer Company warrants its power tables to be free from defects in parts and workmanship under normal use and service for a period of three (3) years from date of shipment. The Brewer Company warrants its exam tables to be free from defects in parts and workmanship under normal use and service for a period of three (3) years from date of shipment. The Brewer Company warrants its lighting products to be free from defects in parts and workmanship under normal use and service for a period of one (1) year from date of shipment. The Brewer Company will not be responsible for any Product failure due to abuse, misuse, modification or improper use or for any use which exceeds the published capacity of the Product. Products returned by prepaid freight for inspection and found defective will, at the option of The Brewer Company, be repaired or replaced at no charge, but no claim for outside labor or other charges will be allowed. Products must not be returned without proper written authorization from The Brewer Company. Requests for authorization must be in writing and accompanied by the original purchase order, The Brewer Company invoice number and a copy of the invoice for the Product. THIS WARRANTY IS EXCLUSIVE AND IN LIEU OF ALL OTHER WARRANTIES AND REMEDIES WHATSOEVER, INCLUDING BUT NOT LIMITED TO IMPLIED WARRANTIES OF MERCHANTABILITY AND/OR FITNESS FOR A PARTICULAR PURPOSE. NO AGENT, EMPLOYEE, OR REPRESENTATIVE OF THE BREWER COMPANY HAS ANY AUTHORITY TO MAKE ANY AFFIRMATION, REPRESENTATION, OR WARRANTY NOT SET FORTH IN THESE TERMS AND CONDITIONS CONCERNING ANY PRODUCTS OF THE BREWER COMPANY. THE BREWER COMPANY SHALL HAVE NO LIABILITY WHATSOEVER FOR DAMAGES CAUSED BY TRANSPORTATION, ACCIDENTS, FIRE, UNAUTHORIZED ALTERATION, OR NORMAL WEAR OR ABUSE, NOR SHALL THE BREWER COMPANY HAVE ANY LIABILITY WHATSOEVER FOR ANY INCIDENTAL OR CONSEQUENTIAL DAMAGES, including without limitation, lost profits or any such damages arising from (a) the design, manufacture, sale, delivery, installation, repair, operation or use of products of The Brewer Company or any part thereof, (b) any actual or alleged failure or defect in products of The Brewer company or any part thereof, or (c) any actual or alleged breach or non-performance by The Brewer Company of this limited warranty.

Freight Claims: Upon receipt, merchandise should be carefully examined to ascertain that proper amount has been received in good condition. Any claim for shortage or damage must be made with delivering carrier within five (5) days from receipt of goods. We do not assume any responsibility for loss or damage in transit, and compensation for such loss must be obtained from the carrier.

NOTES